

# METHODOLOGY FOR DETERMINING THE PARAMETERS OF THE AIR FLOW IN A PNEUMATIC SEPARATOR WITH A CLOSED AIR SYSTEM

*Evgeniy Mikhailov<sup>1</sup>, Doctor of Technical Sciences,  
Nadya Zadosnaia<sup>1</sup>, eng.,  
Nikolaiy. Rubtsov<sup>2</sup>, Ph.D.,  
Plamen Kangalov<sup>3</sup>*

<sup>1</sup>*Tavria State Agrotechnological University*

<sup>2</sup>*Melitopol State Pedagogical University*

<sup>3</sup>*University of Ruse "Angel Kanchev"*

The paper considers the state of grain materials coming from grain harvesters for preliminary cleaning. Preliminary cleaning of grain is to separate large and air-separated impurities from the grain and thereby improve their flowability. This increases their safety during temporary storage. Pre-cleaning is necessary for seed and all food grain after harvesting.

The analysis of work of software tools and methods of their research is conducted. To a lesser extent, studies on the procedure for determining the parameters and operating modes of the scalper type air separator are presented, which determines the relevance of the study.

The device and the technological process of operation of a pneumatic separator with a closed air system are proposed, which pushes the task of developing a methodology for their investigation.

A special novelty in the study of airflow parameters of a pneumatic separator is a two-stage sedimentary chamber and a suction channel of the fan, which influence the validation of airflow parameters in the zone of fluidization of grain materials (ZM) and their pneumoseparation. An important role in this determines the injection airflow, which diametrically permeates a cylindrical sieve.

The state of the air flow structure and the analysis of factors ensuring the quality of cleaning grain material, constitute the main task of the study of the pneumatic separator.

A procedure for determining the airflow parameters of a scalper-type air separator is developed by studying the structure and air speed diagrams in the sections of the air distributor, the pneumatic separating and sedimentation chambers.

The structure and air speed diagrams in the air distributor are studied in five sections. The values of dynamic pressure and air flow are determined. When changing the live cross-section of the air distributor, different values of the angles of inclination of the middle moving and rear moving walls and the coefficient of the live section of the intensifier tray are taken into account.

Based on the obtained data, the working airflow rates are determined, the velocity diagrams are constructed, the structure hydraulic resistance of the pneumatic system is formed. This allows making adjustments to the definition of rational and optimal values of the parameters and modes of operation of pneumatic system. The result is increasing the efficiency of pneumoseparation and reduction of its energy consumption.

**Keywords:** pneumoseparation, grain, airflow, lots of grain, light impurities, dust.

## INTRODUCTION

Grain material after receipt from the harvester includes a mixture of seeds of the main culture; third-party cultivated plants; impurities - damaged and immature grains; weed seeds; chaff; the living and the dead debris; impurities of mineral and organic origin.

The aim of preliminary cleaning of grain is to separate from the grain large impurities and thus improving their flow ability. This improves their safety during temporary storage. Pre-treatment is necessary for seeds and all food grains after harvest.

Adversely affects the machine productivity pre-cleaning the grain heap of high humidity

and contamination [1,2,3]. It is caused primarily by the presence of small weed seeds in the grain material, which leads to its self-separation in kilns dryers. This negatively affects grain quality due to uneven heating and drying.

The grain heap when conducting the pre-cleaning is necessary to divide into factions. It is large and air-separable impurities up to 60% of all impurities, and processed grain with small remnants of non-separated impurities. The presence of impurities in length more than 50 mm are not allowed, and all foreign matter shall be not more than 5%. The presence of full grain in the waste should not exceed 0.02% of the total weight of main crop grain.

Grain cleaning machine pre-cleaning the grains are classified according to the following criteria: – mobility, divisibility rule grain mixture, the type of fan, the of type system air flow, airflow channel, the type of sieves, etc.

At the initial stage of cleaning the separation of components of the heap of grain takes place according to aerodynamic properties and especially the critical speeds of rotation. In this widely used phenomenon of motion of material particles in modern grain cleaning machines associated with the separation of the constituents of the heap. However, the quantitative regularities of the motion of bodies taking into account the resistance of the air environment and require additional research [4-9].

Installation and definition of parameters and regimes of operation of any grain-cleaning machines are an integral part of any study.

Special interest represent a pneumatic grid separator of a grain heap with a closed air system [5], where a device that allows dividing the air flow into two components - separating and feeding - is of great importance.

In the field of grain cleaning, the transfer of a grain heap into a fluidized state is presented in paper [5]. The grain mixture moves along the damper, and the air flow, supplied by the upper channel, passes through the perforated surface of the shutter and the grain layer.

In work [5], the grain material is fed into the feeding device of the pneumatic separating channel by the charging device. On a perforated inclined plane, the grain material is liquefied by an air stream, which is pumped by the fan through the air supply channel. As a result,

light impurities "float up" to the surface of the grain material and enter the air-separation channel above the input zone of the grain part of the starting material.

In work [5] the technique of experimental studies of the separation process on an inertia-gravitational lattice separator is considered, where the determination of physicomachanical properties of grain is envisaged. The mathematical models were tested for adequacy. The regularities of grain sifting through grating sieves are studied depending on the main parameters and operation modes.

To a lesser extent, studies on the procedure for determining the parameters and operating modes of the scalper type air separator are presented, which determines the relevance of the study.

## PURPOSE OF THE STUDY

Development of a technique for determining the airflow parameters of a scalper-type pneumatic separator by studying the structure and air speed diagrams in the sections of the air distributor, the pneumatic separating and sedimentation chambers.

## METHODS OF RESEARCH

A special novelty in the study of airflow parameters of a pneumatic separator is a two-stage sedimentary chamber and a suction channel of the fan, which influence the validation of the air flow parameters in the zone of fluidization of the GM and its pneumo-separation. An important role in this determines the injection airflow, which diametrically permeates a cylindrical sieve.

The state of the air flow structure and the analysis of factors ensuring the quality of cleaning grain material, constitute the main task of the study of the pneumatic separator.

Determination of airflow rates is provided by the technique described in the works of Veselov, SA. [10] and [11]. The structure of the air flow is studied in cross sections perpendicular to the direction of the air flow. To determine the air flow parameters, it is supposed to use devices - the micro-manometer MMN-240 (MMN-2400) with a Pitot-Prandtl tube or a pressure tube of the NIIOGAZ design,

a TTM-2-02 thermo-anemometer, thermo-anemometer TTM-2-02, hot-wire anemometer KIMO VT 50, taking into account DSTU ISO 6584: 2003.

## RESULTS

Based on the carried out studies, a pneumatic separator is proposed, the technological scheme of which is shown in Fig. 1 [11,12]. The technological process of the pneumatic separator is carried out as follows. The air flow from the diametrical fan 1, driven by the direct-current electric motor 2 and the belt drive 3, is directed to the air distribution unit 5. The air flow, due to the control lever of the middle movable wall 6, is distributed to the louvers of the air distributor 7 and the intensifier tray 10.

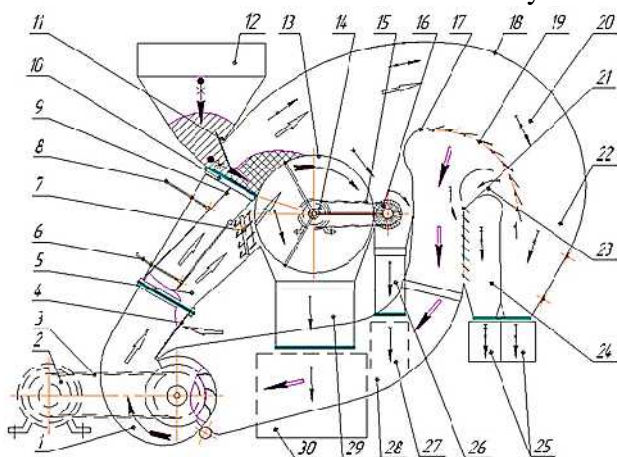

Figure 1. Technological scheme of pneumatic separator

1 - fan diametric; 2 - DC motor; 3 - fan drive; 4 - additional airflow inlet louvers in the fan; 5 - air distributor; 6 - control lever of the middle movable wall; 7 - air distributor blinds; 8 - control lever of the rear movable wall; 9 - extension of the rear movable wall; 10 - tray-intensifier; 11 - shutter of the hopper; 12 - bunker; 13 - cylindrical sieve; 14 - motor-reducer; 15 - brush cleaner drive; 16 - brush cleaner; 17 - airflow cut-off; 18 - shell of the air channel of the sedimentation chamber; 19 - the working surface of the blinds of the 1st stage of cleaning; 20 - air channel of the 1st stage of purification; 21 - the surface of the blinds of the 2nd stage of cleaning; 22 - sedimentation chamber of the 1st stage of purification; 23 - input channel of the 2nd stage of purification; 24 - sedimentation chamber of the 2nd stage of purification; 25 - bunker of impurities of the 1st and 2nd stages of the sedimentation chamber;

26 - the channel and the valve for the withdrawal of large impurities; 27 - bunker of large impurities; 28 - the suction channel of the fan; 29 - channel and valve of the purified grain material; 30 - bunker of purified grain material.

The supply of heap coming from the hopper 12 is controlled by a shutter 11. By changing the position of the extension of the rear movable wall 9, the fluidization state of the grain heap on the tray-intensifier is provided. Here, segregation is carried out - the grain, as the heavier fraction, descends into the lower layer, and the light impurities (straw, unmilled ears) - into the upper layer. Due to the rotation of the cylindrical sieve 13, which is driven by the geared motor 14, the brush cleaner 16 is rotated simultaneously through the drive 15. The grain is spilled through the sieve and enters the hopper 30 through the channel of the purified cereal material 29. Large impurities (straw, ear and others) due to the rotation of the cylindrical sieve are moved to the area of the brush cleaner 16 and through the channel of large impurities 26 enter the bunker of large impurities 27. The air flow is regulated by the louvers 7, pierces the cylinder sieve and partly grain pile. The air-separated contaminants move through channel 20 and enter the zone of the sedimentation chamber of the 1st stage of purification 22. Under the action of centrifugal forces and gravity forces, light impurities (dust, small particles of straw) are pressed against the shell 18 and along the wall of the body moves to the impurity chamber 25. Due to the vacuum created under the working surface of the louvers of the I and II stages of the cleaning of the sedimentation chamber, the air flow is directed to the suction duct of the fan 28. The air flow in the fan is equalized by means of louvers 4. Light impurities enter through the louvre 19 into the inlet channel of the second stage of purification 23 and further into the sediment chamber of the II stage of purification, where they finally settle in the hopper 25. Thus, a closed cycle of operation of the air separator is carried out.

To conduct research, the technological scheme of the pneumatic separator (Fig. 1) will be conditionally divided into two zones - the zone of the air distributor and the pneumatic separating chamber (Fig. 2), and the zone of the

sedimentation chamber (Fig. 3). The separation zone is taken along the Y-axis, passing through the center of the cylindrical sieve 13. The scheme of the laboratory-production plant for removing the characteristics of the air flow in the zone of the air distributor and the pneumatic separating chamber is shown in Fig. 2.

The scheme of the laboratory-production unit for removing the characteristics of the air flow in the zone of the sedimentation chamber is shown in Fig. 3.

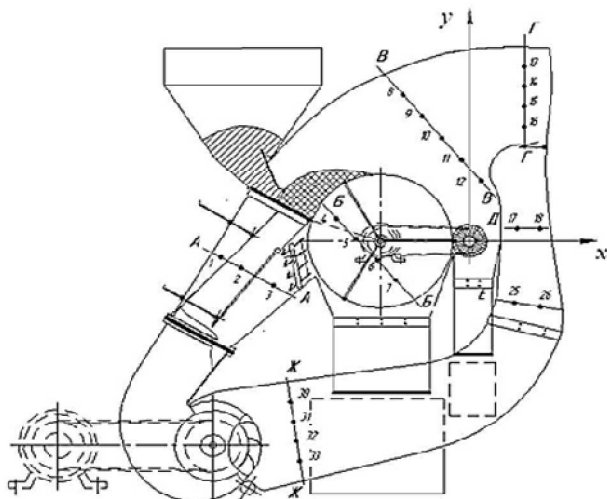

Figure 2 - Scheme of a laboratory-production plant for removing the characteristics of the air flow in the zone of the air distributor and pneumatic separating chamber.

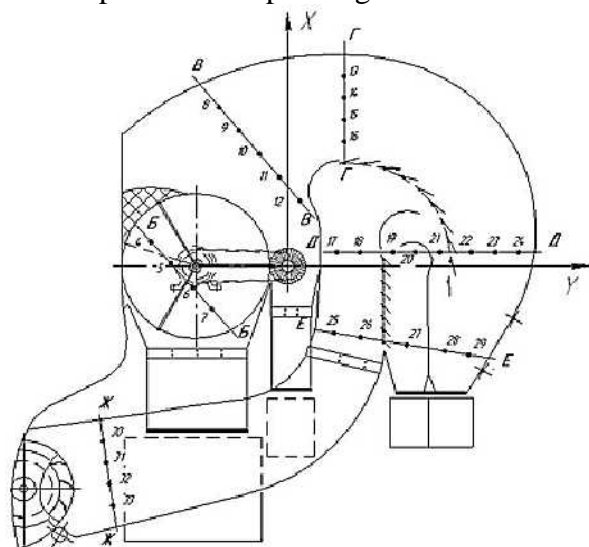

Figure 3 - Scheme of the laboratory-production plant for removing the characteristics of the air flow in the zone of the sedimentary chamber.

*In the zone of the air distributor and the pneumatic separating chamber it is suggested to*

*take into account and change the following factors (Fig. 1):*

- fan speed;
- the angle of inclination of the air flow leaving the air distributor blind to the horizontal;
- the angle of inclination of the rear movable wall of the air distributor to the rear fixed wall;
- the angle of inclination of the moving middle wall to the fixed middle wall of the air distributor;
- length of the intensifier tray;
- the opening value of the hopper flap.

*In the zone of the sedimentary chamber, it is proposed to take into account and change the following factors (Fig. 1):*

- fan speed;
- the area of the "live section" of the blinds of the I-th stage of cleaning;
- the area of the "live section" of the blinds of the second stage of cleaning;
- the opening value of the hopper flap.

To assess the quality of the pneumatic system, we take the completeness of the separation of large, airborne impurities and the loss of high-grade grain into waste.

As an example of placement of cross-sections for measuring airflow parameters in an air distributor, refer to figure 4. Here is a diagram of a laboratory-production installation for determining the main parameters and operating modes of the supply and separation components of the air distributor.

The structure and airspeed diagrams of air velocities in the air distributor are studied in five sections. The values of dynamic pressure and air flow are determined. When changing the "live section" of the air distributor take into account the different values of the angles of inclination of the middle moving and rear moving walls, and the coefficient of the live section of the intensifier tray. Measurements of the air flow parameters are carried out in accordance with [10, 11] in the sections: 0-0 - the cross-section for measuring the dynamic pressure at the inlet to the distributor

I-I - cross-section for measuring the dynamic pressure under the intensifier tray;

II - II - cross section for measuring the dynamic pressure above the intensifier tray;



III - III - section of the measurement of dynamic pressure under the louvered air distributor;

IV - IV - cross section for measuring the dynamic pressure in the separating zone of a cylindrical sieve.

Based on the obtained data, the working airflow rates are determined, velocity profiles are plotted, and the structure of the hydraulic resistances of the pneumatic system is formed. This allows you to make adjustments in determining the rational and optimal values of the parameters and operating modes of the pneumatic system. As a result, it is planned to increase the efficiency of the pneumatic separator and reduce its energy intensity.

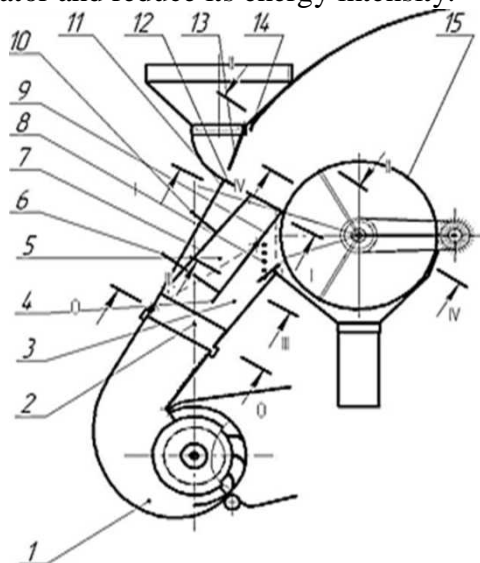

Fig. 4 - Scheme of the laboratory - production installation for determining the main parameters and operating modes of the supply and separation components of the air distributor.

- 1 - the fan diametric; 2 - device of an air distributor; 3 - separating component of the air distributor; 4 - middle movable wall; 5 - feeding component of the air distributor; 6 - the regulator of change of an inclination angle of an average mobile wall; 7 - movable rear wall; 8 - air distributor louvered; 9 - fixed middle wall; 10 - the regulator of a change in the angle of inclination of the rear movable wall; 11 - rear wall; 12 - tray-intensifier; 13 - power supply; 14 - bunker; 15 - cylindrical sieve.

## CONCLUSIONS

1. The state of grain materials coming from grain harvesters for preliminary cleaning is considered.

2. The analysis of the work of the software and the methods of their research, which testifies to the small number of studies of the scalper type pneumatic separators, is conducted.

3. The device and the technological process of operation of a pneumatic separator with a closed air system are proposed, which raises the problem of developing a methodology for their investigation.

4. The technique for determining the airflow parameters of the scalper type air separator is developed by studying the structure and air speed diagrams in the sections of the air distributor, the pneumatic separating and sedimentation chambers.

On the basis of the data obtained, the operating speed of the air flow is determined, and the structure of the hydraulic resistances of the pneumatic system is formed. This allows you to make adjustments in determining the rational and optimal values of the parameters and operating modes of the air separator.

## REFERENCES

Zberihannia i pererobka produktsii roslinnytsva /H. I. Podpriatov, L. F. Skaletska, A. M. Senkov, V. S. Khylevych. — K.: Meta, 2002. — 495

Nachinov D.S. Sovershenstvovanie liniy dlya posleuborochnoj obrabotki zerna /D.S. Nachinov/ Traktory i sel'skohozyajstvennyye mashyny - 2005 god, №1 – s. 17-22

Mykhailov Ye. V., Zadosna N.O., Bilokopytov O.O. Metodyka vyznachennia yakisnykh pokaznykiv roboty povitriarozpodilnoho prystroiu mashyny poperednoho ochyshchennia zerna / Ye.V. Mykhailov, N.O. Zadosna, O.O. Bilokopytov // Mezhdunar. nauk.- prakt. konf. po pytanniam pryrodnoho ahrovyrobnytstva v Ukraini, problem stanovlennia, perspektyv rozvytku. 22-23 zhovtnia 2015 roku u Dnipropetrovskomu derzhavnomu ahroekonomichnomu universyteti. – Dnipropetrovsk, 2015. - S. 60-62.

Mihajlov E. V., Zadosnaya N.A. Aspekty obosnovaniya parametrov i rezhimov roboty pnevmoseparatora maslichnogo syr'ya podsolnechnika / E.V. Mihajlov, N. A. Zadosnaya // MOTROL Commission of Motorization and Power industry in Agriculture

Polish Academy of Sciences Branch in Lublin, –Volume 17, № 9. –2015, – p. 43 – 49.

Mykhailov Ye. V., Zadosna N.O. Uslovyia obosnovanyia parametrov y rezhymov roboty pnevmoseparatora maslychnoho syria podsolnechnyka / Ye.V. Mykhailov, N.O. Zadosna// Problemy konstruiuvannia, vyrobnytstva ta ekspluatatsii silskohospodarskoi tekhniky: X Mezhdunar. nauk.- prakt. konf. 5-6 lystopada 2015 r. –Kirovohrad, 2015. -S. 96-98.

Mykhailov Ye. V., Zadosna N.O. Peredumovy vyznachennia parametriv i rezhymiv roboty mashyny poperednoi ochystky zerna / Ye.V. Mykhailov, N.O. Zadosna // Pratsi Tavriiskoho derzhavnogo ahrotekhnolohichnoho universytetu. - Melitopol, 2015. - Vyp. 15, t. 4. - S. 167-173.

Mykhailov Ye.V., Afanasiev O.O., Zadosna N.O. Udoskonalennia pnevmose-paruiuchoi kamery pnevmoreshitnoho separatora iz zamknenoiu povitrianoi systemoiu. / Ye.V. Mykhailov, O.O. Afanasiev, N.O. Zadosna// Visnyk Sumskoho natsionalnoho ahrarnoho universytetu. - Sumy, 2016. – Vyp.10, t. 2. – S. 96 - 99.

Mykhailov Ye.V., Afanasiev O.O., Zadosna N.O. Pnevmoreshitnyi separator iz zamknenoiu povitrianoi systemoiu. / Ye.V. Mykhailov, O.O. Afanasiev, N.O. Zadosna// Suchasni problemy zemlerobskoi mekhaniky: XVII Mezhdunar. nauk. konf. 17 - 18 zhovtnia 2016 r. – Sumy , 2016. - S. 56 - 58.

Veselov S.A. Praktikum po ventilyatornym ustanovkam. / S.A. Veselov // -2-e izd. pererab. i dop.- M.: Kolos, 1982. - 255s.

DSTU ISO 6584:2003 Ustatkuvannia ochysne dlia povitria ta inshykh haziv. Klasyfikatsiia pylovlovliuvachiv – K: Derzhstandart Ukrainy, 2003.

Pat. № 97812 U Ukraina, MPK V07V1/28. Pnevmoreshitnyi separator /Ie. V. Mykhailov, N.O. Zadosna - № u2014 07545; zaiavl.04.11.2014; opubl. 25.04.2015, Biul. № 12.

Pat. № 98383 U Ukraina, MPK V07V1/28. Pnevmoreshitnyi separator/Ie. V. Mykhailov, N.O. Zadosna - № u2014 12226; zaiavl.13.11.2014; opubl. 27.04.2015, Biul.№ 8.