

UDC 631.356.02

# MATHEMATICAL MODELLING OF THE MOVEMENTS OF TRACTOR WORKING TOOLS IN CONTROLLED TRAFFIC FARMING

V. V. Adamchuk <sup>1</sup>, V. M. Bulgakov <sup>2</sup>, I. V. Holovach <sup>2</sup>, V. P. Kuvachov <sup>3</sup>

<sup>1</sup> National Scientific Center "Institute for Agricultural Engineering and Electrification" NAAS of Ukraine  
11, Vokzalna Str, vil. Hlevakha-1, Vasylkivsky District, Kyiv Region, Ukraine, 08631

<sup>2</sup> National University of Life and Environmental Sciences of Ukraine  
15, Heroyiv Oborony Str., Kyiv, Ukraine 03041

<sup>3</sup> Tavria State Agrotechnological University  
18, B. Khmelnytskoho prov., Melitopol, Zaporizhzhia Region, Ukraine, 72310

e-mail: nnc-imesg@ukr.net: vbulgakov@meta.ua

Received on September 11, 2017

The main index of quality work of wide-span tractors for controlled traffic farming is the scale of damaging the plants with the working tools. Damaging the plants is considerably dependent on the scope of transversal deviations of the working tools which is conditioned by the movement stability of the wide-span tractor and some deviation from the trajectory of the established controlled traffic farming and working tools in the field dimension. Therefore, the study of the transversal movement of the working tools of a wide-span tractor and the impact of their deviations on the quality of implementing the technological process requires in-depth research and substantiation of constructive and kinematic parameters, which would ensure high quality of their work within the controlled traffic farming system. **Aim.** To enhance the work quality of the wide-span tractors using the elaborated mathematical model of transversal deviations of the working tools, which would allow substantiating the constructive and kinematic parameters as well as the scope of the protection zone, based on condition of avoiding damage to the plants. **Methods.** The methods of building estimated mathematical models for the functioning of agricultural machines and equipment, based on theoretical mechanics, advanced mathematics, and the probability theory were used. **Results.** The article offers the methods of determining kinematic parameters of wide-span tractors and the probability of damaging plants in a row, which provide for substantiated selection of distances between the kinematic center of the tractor and the center of resistance of the device, used to lay the controlled traffic farming, and the working tools as well as for selection of the scope of the protection zone with the consideration of their constructive parameters, stability and movement controllability. New mathematical dependences were elaborated, the application of which allows determining permissible thresholds of transversal deviations of the working tools, remarkable for standard deviation in agrotechnical conditions regarding the damage to plants in a row, which takes place while estimating the working indices of wide-span tractors in the controlled traffic farming. **Conclusions.** The optimal zone of placing the devices for controlled traffic and working tools is concentrated on minimally possible longitudinal distance from the kinematic center of the tractor. The factor of deviation difference should be taken into consideration while placing the working tools for wide-span tractors.

**Keywords:** controlled traffic farming, wide-span tractor, damaging the plants, transversal deviations.

**DOI:**

## INTRODUCTION

Wide-span tractors for controlled traffic farming are getting more popular in the world [1–3]. The main quality index of their work is the scope of damaging the plants with working tools. The major reason of damag-

ing plants is large-scale deviation of the working tools, which are the farthest from the center of tracking the movement of the wide-span tractor. Transversal deviations of the working tools depend on the movement stability of the wide-span tractor, which results from the impact of many factors: uneven resistance of soil,

type of an agent, and its moment of resisting the turn, speed of movement, effective forces, etc. Due to the fact that their track width exceeds the wheelbase several times, the course angular and transversal deviation leads to considerable shifts of the working tools, especially the farthest ones, which impacts damaging the plants in a row.

Another reason of damaging the plants is some difference in the trajectory of the controlled traffic and the working tools of wide-span tractors in the field. The nature of this phenomenon lies in the fact that the kinematic center of the tractor does not coincide with the axis, passing through the tracking point for its movement trajectory. For instance, in widely common samples of the mentioned tractors, which are girder tractors ASA-Lift WS 9600 WS [4], Douler [5], BIOTRAC [6] and others, the cabin with the tracking-steering system or the steering agent is located on one side. The very movement trajectory of the mentioned wide-span tractors is conditioned with parameters of controlled traffic. The latter is usually formed using special equipment, for instance [7]. For the mutual deviation of the formed trajectory of the controlled traffic and the working tools to be minimal, which is the condition of quality work, it is necessary either to minimize the amplitudes of transversal shifts of the working tools, or to achieve the synchronous oscillations of the trajectories of the controlled traffic and the working tools for each frequency.

The study of the movement stability of specialized wide-span tractors is the object of a special study, rather sufficiently covered in [8–11], thus, it is not viewed in this work. The task is to determine mathematical relations, which allow determining the qualitative impact of constructive and kinematic parameters of a wide-span tractor on the value of transversal deviations of the working tools, and, depending on the scope of the protection zone, – the impact on the damaging of plants in the row.

When a high level of automatization of driving the known wide-span tractors is taken into account, it is not deemed possible to minimize the amplitudes of transversal deviations of the working tools. Then, ensuring the synchronous trajectory of the stable technological track and the working tools in the field is the actual way of improving the work quality.

Therefore, the study of the transversal movement of the working tools of a wide-span tractor and the impact of their deviations on the quality of implementing

the technological process require in-depth research and substantiation of constructive and kinematic parameters, which would ensure high quality of their work within the controlled traffic farming system.

The aim of the study was to elaborate the mathematical model of transversal deviations of the working tools of a wide-span tractor, which would allow substantiating some of its constructive and kinematic parameters as well the scope of the protection zone, based on the conditions of avoiding damage to plants.

## MATERIALS AND METHODS

The methods of building computational mathematical models for the functioning of agricultural machines and equipment, based on theoretical mechanics, advanced mathematics and the probability theory were used in the theoretical research.

## RESULTS AND DISCUSSION

Let us apply the kinematic point of view to consider the main factors, impacting the transversal deviation of the tools for controlled traffic, and the working tools of a wide-span tractor, moving along the formed controlled traffic (Fig. 1).

As the number of kinematic parameters of a wide-span tractor is high, and the threshold of their variation is wide, let us make a mathematical model first, which would reflect the value of the amplitude of the mutual deviation of trajectories of the controlled traffic and the working tools. To turn off the impact of the tracking-steering system, the model was created for the case of ideal copying of the given trajectory of the equipment by the tracking point in order to lay the tracks of controlled traffic. This would allow modelling the tractor movement while laying the tracks of controlled traffic and the working movement as one multi-link elastic-framed vehicle.

Let us assume that in actual conditions the mentioned trajectories are periodic oscillations, which may be expressed by a sum of the final number of sinusoids:

$$\tilde{O} = \sum_{i=1}^n A_i \cdot \sin\left(\frac{2\pi}{T_i} y + \varphi_i\right), \quad (1)$$

where  $A_i$ ,  $T_i$ ,  $\varphi_i$  – amplitude, period, and phase of transversal oscillations of the working tools at  $i$ -frequency;  $n$  – the number of intervals in the line of passing the frequencies of a wide-span tractor;  $y$  – the length of the way.

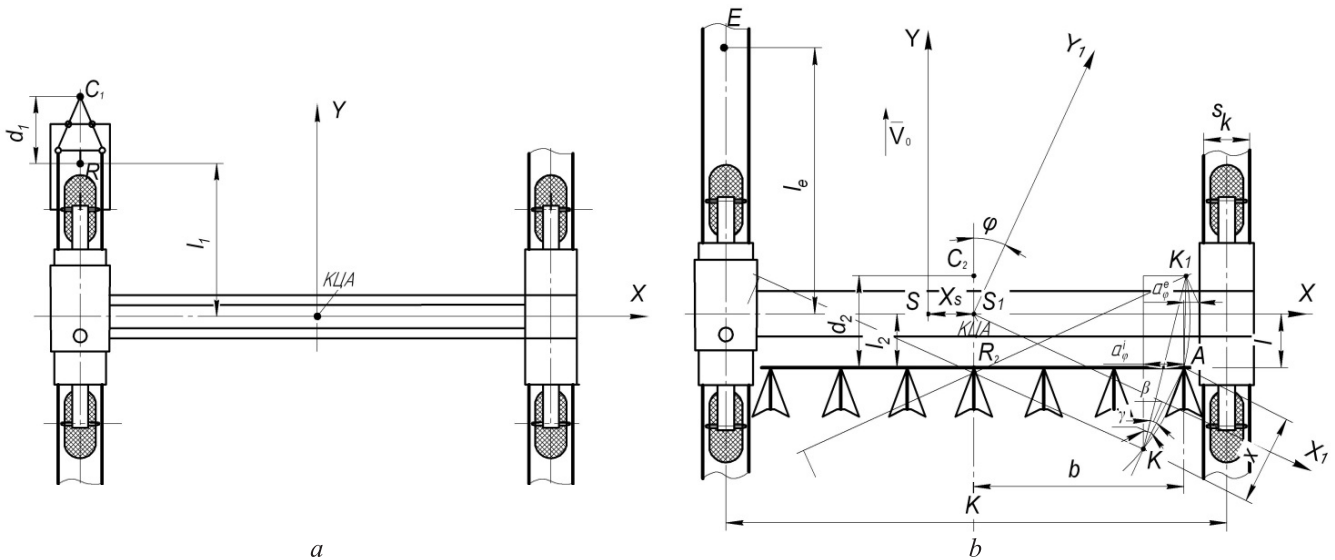

**Fig. 1.** The scheme of a wide-span tractor in the composition of equipment for controlled traffic (a) and the working tools (b)

If one assumes that the spectra of trajectory frequencies of controlled traffic and the working movement of a wide-span tractor coincide, when the trajectories of their working tools are superposed, the mutual deviation of the latter may be expressed with the relation (1) with the change in values of amplitudes and phases. The transversal deviations of the working tools from the given movement direction of the kinematic center of the tractor (KCT, see Fig. 1), while laying the tracks of controlled traffic along the sinusoid  $A_{0i}$  and period  $T_i$  are approximately expressed in the relations, built using the method [12]:

$$X_{1i} = A_{0i} \frac{T_i^2 + 4\pi^2(l_1 + d_1)d_1}{T_i^2 + 4\pi^2d_1^2} \sin\left(\frac{2\pi}{T_i}(y-l_1)\right) + A_{0i} \frac{2\pi T_i l_1}{T_i^2 + 4\pi^2d_1^2} \cos\left(\frac{2\pi}{T_i}(y-l_1)\right); \tag{2}$$

$$X_{2i} = \frac{A_{0i} T_i}{(T_i^2 + 4\pi^2d_1^2)(T_i^2 + 4\pi^2l_e^2)(T_i^2 + 4\pi^2d_2^2)} \times \{ (T_i^2 + 4\pi^2(l_1 + d_1)d_1) \cdot (T_i^2 + 4\pi^2(l_2 + l_2d_2 + d_2^2)) \pm 4\pi^2l_1((l_e - l_2)T_i^2 + 4\pi^2l_e d_2(l_2 + d_2)) \} \sin\left(\frac{2\pi}{T_i}(y - l_1 \pm l_e \mp l_2)\right) + 2\pi \{ l_1 T_i [T_i^2 + 4\pi^2(l_2 + l_2d_2 + d_2^2)] \pm [T_i^2 + 4\pi^2(l_1 + d_1)d_1] \times [T_i(l_2 - l_e) - \frac{4\pi^2l_e d_2}{T_i}(l_2 + d_2)] \} \cos\left(\frac{2\pi}{T_i}(y - l_1 \pm l_e \mp l_2)\right) \tag{3}$$

where  $l_1$  and  $d_1$  – longitudinal distances from the resistance center  $R_1$  of the tool of controlled traffic to the kinematic center of the tractor, and instantaneous center of the turn  $C_1$ , see Fig. 1, a;  $l_2$  and  $d_2$  – longitudinal distances from the resistance center  $R_2$  of the working tools to the kinematic center of the tractor and instantane-

ous center of the turn  $C_2$ , see Fig. 1, b;  $l_e$  – longitudinal distance from the tracking center  $E$  according to the trajectory of the working movement of the tractor to its kinematic center, see Fig. 1, b.

In formula (3) the double sign «±» or «∓» is used for the direction of the working movement of the tractor: upper sign – along controlled traffic, lower sign – against the traffic.

The value of mutual deviations of controlled traffic and the working tools of a wide-span tractor, accepted for the target function, will be expressed in the formula:

$$\Delta X_i = X_{2i} - X_{1i} \rightarrow \min \tag{4}$$

The task of optimization in each i-th frequency of oscillations and the accepted direction of the working movement of a wide-span tractor comes down to the selection of several variants of parameter ratios  $l_1, l_2, d_1, d_2, l_e, l_1$ , which will ensure minimization of  $\Delta X_i$ . The values of periods  $T_i$  are selected in the band of passing the frequencies of the wide-span tractor with an even step  $\Delta T_i = 10$  m, i.e.  $T_1 = 10$  m,  $T_2 = 20$  m, etc. The consideration of oscillations with the period, exceeding 50 m, is senseless as such trajectories may be considered practically linear.

The results of calculations are presented in Table 1.

The calculations demonstrated that from the kinematic standpoint, the optimal zone of placing the tools for controlled traffic and working tools is concentrated at a minimally possible distance from the kinematic center of the tractor. The optimal longitudinal distance from the kinematic center of the trac-

tor to the tracking point for the movement trajectory is 3–4 m.

If the tools of controlled traffic are placed further from the kinematic center of the tractor, there should be rigid fixing. The working tools should have flexible fixing here, and be placed from the resistance center at a minimally possible distance from the tools of controlled traffic.

Let us elaborate mathematical relations which would allow defining the permissible threshold of transversal deviations of the working tools of a wide-span tractor and substantiating the value of the protection zone, based on condition of avoiding damage to plants. Here we will take into consideration that the total deviation of a separate working tool consists of deviation  $X_s$  of the center of the tractor (t.  $S$ ) from the given movement trajectory and its own shift due to angular deviation (see Fig. 1).

The deviation of the center of a wide-span tractor takes place due to the simultaneous effect of many independent variable factors [8–11], thus it may be in agreement with the law of normal distribution. Though this fact requires experimental confirmation, we will make this assumption at this stage of our studies. The transversal deviations of the working tools due to angular turns of the tractor depend on the value of the latter, which changes all the time, and parameters, characterizing their placement. As known from the probability theory, the presence of independent variable factors in the total amount, acting on one of the prevailing processes, may lead to inconsistency of the law of normal distribution. This is the case for transversal deviation of the working tool, where a constant factor, affecting

the process, is a parameter, characterizing its location in the device.

Let us assume that curves 1 and 2 (Fig. 2) characterize the density of locating the probability of deviations of separate working tools of a wide-span tractor from the given direction of movement  $Y_l - Y_l$  and location of plants regarding the axis of the row  $Y_r - Y_r$ . The leg  $Z$  is the zone of possible location of the working tool with some probability  $p(X_{iz})$  and the location of plants with probability  $p(X_{rz})$ .

Then the probability of damaging the plants  $p(D_z)$  in the zone  $Z$  may be defined based on the theorem of multiplying the probability [13]:

$$\delta(Dz) = p(X_{iz} \cdot X_{rz}) = p(X_{iz}) \cdot p(X_{rz}) \quad (4)$$

If the protection zone  $C$  is sufficiently large, so that curves 1 and 2 (see Fig. 2) do not cross, then the zone  $Z$  is absent and there will be no damage of plants via cutting with the working tool. Using Fig. 2, we find the values for boundaries for  $X_{lr}$  and  $X_{lr}$  of zone  $Z$ :

$$\begin{aligned} X_{lr} &= C - n\sigma_{Xr} \\ X_{lr} &= C - n\sigma_{Xr} \end{aligned} \quad (5)$$

where  $\sigma_{Xl}$  and  $\sigma_{Xr}$  – average deviation of the working tool and location of plants;  $n\sigma_{Xl}$  and  $n\sigma_{Xr}$  – threshold of deviations, where the value  $n$  may be reliably accurately accepted as equal to 3;  $C$  – the value of the protection zone.

The probability of finding the working tool  $p(X_{iz})$  in the zone  $Z$  in the general form may be expressed via the function of location  $F(n\sigma_{Xl})$  and  $F(X_{lr})$  and the density of probability [14]:

$$p(X_{iz}) = \delta(X_{lr} < X_{iz} < n\sigma_{Xl}) = F(n\sigma_{Xl}) - F(X_{lr}) = \int_{-\infty}^{n\sigma_{Xl}} f(X_l) dx - \int_{-\infty}^{X_{lr}} f(X_l) dx. \quad (6)$$

The values of kinematic parameters of a wide-span tractor and mutual deviations of trajectories of controlled traffic and the working tools

Kinematic parameters, m					The mutual deviations of the trajectories of controlled traffic and the working tools, m, in case of oscillations with the period $T_b$ , equal, m:				
$l_1$	$d_1$	$l_2$	$d_2$	$l_e$	10	20	30	40	50
0	0	0	0	4	0.0004	0.0004	0.0004	0.0004	0.0004
2	1	2	1	4	0.182	0.035	0.011	0.005	0.003
2	20	2	1	4	0.156	0.095	0.064	0.046	0.036
4	50	3	0	3	0.095	0.153	0.119	0.094	0.076
0	0	0	0	4	0.0004	0.0004	0.0004	0.0004	0.0004
2	1	2	1	4	0.182	0.035	0.011	0.005	0.003
2	20	2	1	4	0.156	0.095	0.064	0.046	0.036
4	50	3	0	3	0.095	0.153	0.119	0.094	0.076

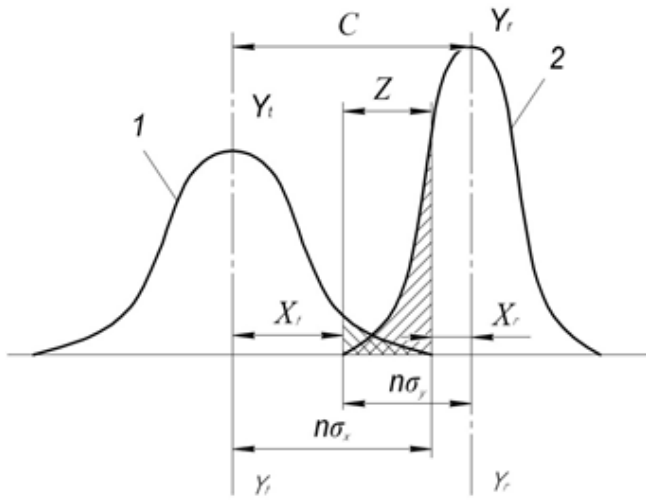

**Fig. 2.** The scheme of the density of probabilities for deviations of the working tools from the given direction of movement *l* and the location of plants regarding the axis of the row *2*

Let us similarly present the probability of placing the plants  $p(X_{rz})$  in the same zone:

$$p(X_{rz}) = \delta(-n\sigma_{Xr} < -X_{rz} < -X_{lr}) = F(-X_{lr}) - F(-n\sigma_{Xr}) = \int_{-\infty}^{-X_{lr}} f(X_r) dx - \int_{-\infty}^{-n\sigma_{Xr}} f(X_r) dx. \quad (7)$$

Setting (6) and (7) into (4) and considering the equations (5), we will obtain the probability of damaging the plants, expressed via the density of probability of deviations of the working tools and the location of plants:

$$\delta(D_z) = \left[ \int_{-\infty}^{n\sigma_{Xl}} f(X_l) dx - \int_{-\infty}^{-n\sigma_{Xr}} f(X_r) dx \right] \cdot \left[ \int_{-\infty}^{-C-n\sigma_{Xl}} f(X_r) dx - \int_{-\infty}^{-n\sigma_{Xr}} f(X_r) dx \right]. \quad (8)$$

In case of normal law of location, if we take the known dependence of normalized density of probability [14] and introduce the relative signs of integral functions, the equation (8) will look as follows:

$$\delta(D_z) = \left[ F(n)_{X_l} - F\left(\frac{C-n\sigma_{Xr}}{\sigma_{Xl}}\right) \right] \cdot \left[ F(n)_{X_r} - F\left(\frac{C-n\sigma_{Xl}}{\sigma_{Xr}}\right) \right], \quad (9)$$

$$F(n)_{X_l} = \frac{1}{\sqrt{2\pi}} \int_{-\infty}^n e^{-\frac{t^2}{2}} dt_{X_l},$$

$$F(n)_{X_r} = \frac{1}{\sqrt{2\pi}} \int_{-\infty}^n e^{-\frac{t^2}{2}} dt_{X_r},$$

where

$$F\left(\frac{C-n\sigma_{Xr}}{\sigma_{Xl}}\right) = \frac{1}{\sqrt{2\pi}} \int_{-\infty}^{\frac{C-n\sigma_{Xr}}{\sigma_{Xl}}} e^{-\frac{t^2}{2}} dt_{X_l},$$

$$F\left(\frac{C-n\sigma_{Xl}}{\sigma_{Xr}}\right) = \frac{1}{\sqrt{2\pi}} \int_{-\infty}^{\frac{C-n\sigma_{Xl}}{\sigma_{Xr}}} e^{-\frac{t^2}{2}} dt_{X_r},$$

$$t_{X_l} = \frac{X_l}{\sigma_{Xl}}; dt_{X_l} = \frac{dX_l}{\sigma_{Xl}}; t_{X_r} = \frac{X_r}{\sigma_{Xr}}; dt_{X_r} = \frac{dX_r}{\sigma_{Xr}}.$$

The equation (9) is just for the assumption, according to which the distribution of deviations of the working tools and location of plants in the row is in good agreement with the normal law (Laplace-Gauss law). However, due to the fact that for traditional machine-tractor aggregates, the “external” and “internal” deviations of the same working tool are uneven for the same angular oppositely directed deviations of the tractor [15], it is probable to expect the same result for the wide-span tractor. The latter cannot but reflect on the character of distributing the whole aggregate of transversal deviations of the working tool of a wide-span tractor.

Using Fig. 1 we find that the kinematic “internal” deviation of the working tool (see *t. A* of the working tool) at the expense of angular deviation of the tractor for angle  $\varphi$ , equals:

$$\alpha_\varphi^i = x \sin(\gamma + \beta) = x(\sin\gamma \cdot \cos\beta + \cos\gamma \cdot \sin\beta), \quad (10)$$

where  $x = KA = AK_1$  – deviation of the working tool;  $\gamma$  – angle, which depends on constructive parameters of the tractor (*b, l*);  $\beta$  – angle, which depends on the value of angular deviation of the tractor  $\varphi$ .

Similarly, for external deviation of the working tool:

$$\alpha_\varphi^e = x \cos(\gamma + \beta) = x(\cos\gamma \cdot \cos\beta - \sin\gamma \cdot \sin\beta). \quad (11)$$

After expressing the values of the right part of equations (10) and (11) via constructive parameters *b* and *l* of the tractor, and the direction angle  $\varphi$ , we shall receive the following dependencies of transversal deviations of the working tool:

$$\alpha_{\varphi}^i = l \sin\varphi + b(1 - \cos\varphi);$$

$$\alpha_{\varphi}^e = l \sin\varphi - b(1 - \cos\varphi). \quad (12)$$

where *b* and *l* – the distances from the longitudinal and transversal axes of the wide-span tractor, which goes through its center, to the working tool.

For the farthest working tool, the constructive parameter *b* in relations (12) is in proportion to the width of the track of the wide-span tractor, which, based on Fig. 2 may be presented as:

$$2b_k = K - 2e \quad (13)$$

where  $b_k$  – the distance from the transversal axis of the wide-span tractor, which goes through its center, to the

farthest working tool;  $K$  – the value of the track of the wide-span tractor;  $e$  – technological zone.

Let us assume that the technological zone according to Fig. 2 is defined by the width of the controlled traffic  $s_k$  and the scope of the protection zone  $C$ :

$$\hat{a} = 0.5s_k + \tilde{N}. \tag{14}$$

Taking into consideration relations (13) and (14), the equations (12) of transversal deviations for the farthest working tool will look as follows:

$$\begin{aligned} \alpha_\varphi^i &= l \sin\varphi + (0.5\hat{E} - 0.5s_k - \tilde{N})(1 - \cos\varphi); \\ \alpha_\varphi^e &= l \sin\varphi - (0.5\hat{E} - 0.5s_k - \tilde{N})(1 - \cos\varphi). \end{aligned} \tag{15}$$

As seen from the equations obtained (15), the internal and external deviations of the working tools are not equal ( $\alpha_\varphi^i \neq \alpha_\varphi^e$ ) for the same angular deviation of the tractor for the value  $\varphi$ . The value of the quantitative change in the internal  $\alpha_\varphi^i$  and external  $\alpha_\varphi^e$  deviation of the farthest working tool depending on the angular deviation  $\varphi$  of the tractor with the different values of its track  $K$  may be observed in Fig. 3.

As seen in Fig. 3, the difference in the shifts of the farthest working tools increases with the increase in the track of the tractor  $K$  and the angle of deviation  $\varphi$ . The difference between deviations is insignificant for slight changes of the mentioned parameters. Thus, one should consider the factor of the difference in deviations of the working tools (especially the farthest ones) for wide-span tractors, as it tells on the asymmetry of distribution.

Thus, if singular shifts of the working tool from the given movement direction to opposite sides are uneven, their combinations will not be equal either. It is not hard to confirm this fact if the right part of equations (15) will have the value of the average angular deviation of the tractor instead of the singular value of angle  $\varphi$ . Here we will obtain the average deviation of the working tool, which corresponds to the average angular deviation of the tractor.

The application of the simple change in singular (random) values for average ones within small values of angles  $\varphi$  is quite acceptable, as the mentioned equations present a linear function for this condition and it is not necessary to conduct any linearization.

Taking the abovementioned into consideration, the equations (15) will look as follows:

$$\begin{aligned} \sigma_{\alpha_\varphi^i} &= l \sin\sigma_\varphi + b(1 - \cos\sigma_\varphi); \\ \sigma_{\alpha_\varphi^e} &= l \sin\sigma_\varphi - b(1 - \cos\sigma_\varphi), \end{aligned} \tag{16}$$

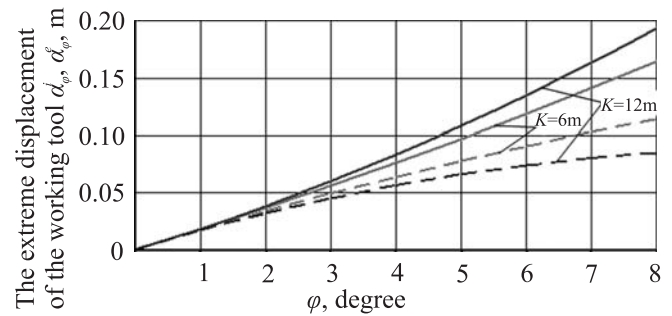

Fig. 3. The internal  $\alpha_\varphi^i$  (—) and external  $\alpha_\varphi^e$  (---) shifts of the farthest working tool depending on the angular deviation  $\varphi$  of the tractor with different values of its track  $K$

where  $\sigma_{\alpha_\varphi^i}, \sigma_{\alpha_\varphi^e}$  – average deviations of the internal and external shifts of the working tool at the expense of the angular deviations of the tractor;  $\sigma_\varphi$  – average deviation, characterizing the combination of all the angular deviations of the tractor from the given direction of the movement.

As the shift of the working tool at the expense of angular deviations of the wide-span tractor is a constituent of total shifts, the latter are not even for its opposite deviations either:

$$\Delta\sigma_{\alpha_\varphi} = \sigma_{\alpha_\varphi^i} - \sigma_{\alpha_\varphi^e} = 2b(1 - \cos\sigma_\varphi) \tag{17}$$

$\Delta\sigma_{\alpha_\varphi}$  – the absolute difference between the internal and external shifts of the working tool from the average course angular deviation of the wide-span tractor.

The obtained equation (17) demonstrates that the absolute difference in the shifts of the working tool due to angular deviations of the wide-span tractor depends considerably on its constructive parameter  $b$ . The value of quantitative change in the difference between the average deviation of the working tool of the wide-span tractor depending on its average angular deviation for different values of  $b$  may be observed in Fig. 4.

Based on Fig. 4, the assumption may be made that the wider the track of the wide-span tractor, and thus, the longer distance is from its longitudinal axis, going through the center, to the working tool, the more significant the difference between the internal and external average deviations is. The latter is more evident with the increase in the average angular deviation, characterizing the combination of all the angular deviations of the mentioned tractor from the given direction of movement. Thus, a conclusion may be made that the automatization of managing the movement of the wide-span tractor with the purpose of decreasing the combination of all its angular deviations from the given direction of

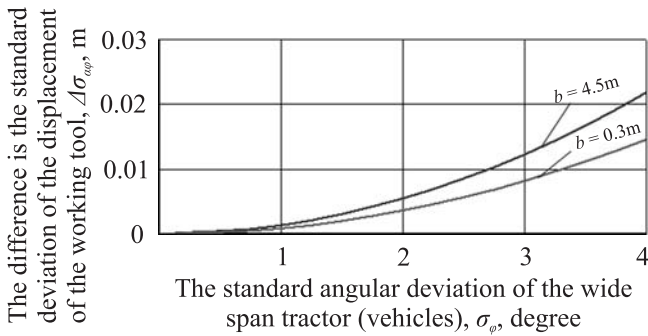

**Fig. 4.** The difference between the internal and external average shifts of the working tool from the average angular deviation of the wide-span tractor with different values of  $b$

movement will allow reducing the probability of cutting the plants in a row with working tools, especially the farthest ones.

Let us consider the damage to the plants with the consideration of asymmetry of the distribution of shifts of the working tools.

Let us assume that curves 1 and 3 (Fig. 5) characterize the density of the asymmetrical distribution of probability of transversal shifts of the working tools, located on both sides of the row, and curve 2 – location of plants. It is evident that the probability of the left working tool occurring in the zone  $Z_l$  does not equal the probability of the right working tool occurring in the zone  $Z_r$  (the areas of shaded parts of the zone  $Z_l$  and  $Z_r$  legs 1 and 3 are uneven), *i.e.*

$$p(X_{z_l}) \neq p(X_{z_r}). \tag{18}$$

The same is true for the location of plants:

$$p(X_{r_z}) \neq p(X_{l_z}). \tag{19}$$

The damage to plants by the left and right working tools is generally defined as:

$$\begin{aligned} p(D_{z_l}) &= p(X_{l_z} \cdot X_{r_z}) = p(X_{l_z}) \cdot p(X_{r_z}); \\ p(D_{z_r}) &= p(X_{l_z} \cdot X_{r_z}) = p(X_{l_z}) \cdot p(X_{r_z}). \end{aligned} \tag{20}$$

As the right parts of equations (20) are not even, then  $p(D_{z_l}) \neq p(D_{z_r})$ . Therefore, we come to the conclusion that the damage to plants due to cutting on condition of the same protection zone  $\tilde{N}$  is different for the left and right working tools. The difference in damage increases with the increase in asymmetry of the curves of distribution of the deviations of the working tools and plants.

To determine the probability of damaging the plants in this case, it is reasonable to use the distribution law, taking into consideration the excess and asymmetry of

the distribution [14]. The function of density for the given distribution is expressed with the sufficient degree of accuracy with the equation [14]:

$$f_A(X) = f(X) - \frac{r_3}{6} f^{(2)}(X) + \frac{r_4-3}{24} f^{(3)}(X), \tag{21}$$

where  $f(X)$  – the normal function of distribution density;  $f^{(j)}(X)$  –  $j$ -th derivatives of the normal function of distribution density;  $r^3, r^4$  – the main moments.

Thus, the probability of damaging the plants with the left and right working tools regarding the axis of the row will be defined as follows:

$$\delta_A(D_{z_e}) = \left\{ \left[ F(n)_{X_l} - \frac{r_3}{6} f^{(2)}(n)_{X_l} + \frac{r_4-3}{24} f^{(3)}(n)_{X_l} \right] - \left[ F\left(\frac{C-n\sigma_{X_l}}{\sigma_{X_l}}\right) - \frac{r_3}{6} f^{(2)}\left(\frac{C-n\sigma_{X_l}}{\sigma_{X_l}}\right) + \frac{r_4-3}{24} f^{(3)}\left(\frac{C-n\sigma_{X_l}}{\sigma_{X_l}}\right) \right] \right\} \times \tag{22}$$

$$\times \left\{ - \left[ F\left(-\frac{C-n\sigma_{X_l}}{\sigma_{X_l}}\right) - \frac{r_3}{6} f^{(2)}\left(-\frac{C-n\sigma_{X_l}}{\sigma_{X_l}}\right) + \frac{r_4-3}{24} f^{(3)}\left(-\frac{C-n\sigma_{X_l}}{\sigma_{X_l}}\right) \right] - \left[ F(-n)_{X_l} - \frac{r_3}{6} f^{(2)}(-n)_{X_l} + \frac{r_4-3}{24} f^{(3)}(-n)_{X_l} \right] \right\}$$

$$\delta_A(D_{z_e}) = \left\{ \left[ F\left(-\frac{C-n\sigma_{X_l}}{\sigma_{X_l}}\right) - \frac{r_3}{6} f^{(2)}\left(-\frac{C-n\sigma_{X_l}}{\sigma_{X_l}}\right) + \frac{r_4-3}{24} f^{(3)}\left(-\frac{C-n\sigma_{X_l}}{\sigma_{X_l}}\right) \right] - \left[ F(-n)_{X_l} - \frac{r_3}{6} f^{(2)}(-n)_{X_l} + \frac{r_4-3}{24} f^{(3)}(-n)_{X_l} \right] \right\} \times \tag{23}$$

$$\times \left\{ \left[ F(n)_{X_l} - \frac{r_3}{6} f^{(2)}(n)_{X_l} + \frac{r_4-3}{24} f^{(3)}(n)_{X_l} \right] - \left[ F\left(\frac{C-n\sigma_{X_l}}{\sigma_{X_l}}\right) - \frac{r_3}{6} f^{(2)}\left(\frac{C-n\sigma_{X_l}}{\sigma_{X_l}}\right) + \frac{r_4-3}{24} f^{(3)}\left(\frac{C-n\sigma_{X_l}}{\sigma_{X_l}}\right) \right] \right\}$$

To study the probability of damage to plants based on the value of the protection zone of the row, let us assume that the average deviations of the shifts of the working tools of the tractor and the location of plants regarding the axis of the row are approximately equal  $\sigma_{X_l} \approx \sigma_{X_r}$ . This assumption is quite reasonable, if the desired constructive, technological and other parameters of the wide-span tractor and its high level of automatization of driving ensure the acceptable stability and management of the movement, as it follows from the analysis of studies, presented in [8–11].

The result of estimating the probability of damage to plants using the example of a wide-span tractor ASA-Lift WS 9600 WS depending on the scope of the protection zone of the row is presented in Fig. 6. The mentioned chart demonstrates that with even scope of the protection zone, the damage to plants with the working tools, located externally regarding the geometric axis of the row and the center of the tractor (curve 2) and inside (curve 1) is different. For instance, with the pro-

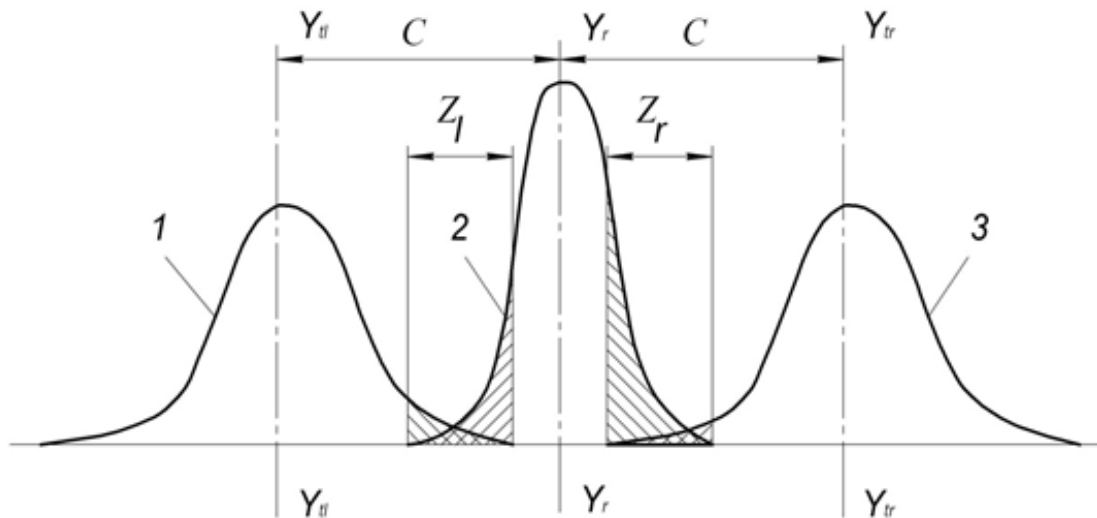

**Fig. 5.** The scheme of the density of the asymmetrical distribution of the probability in the shifts of the left 1 and the right 2 working tools on both sides of the row from the given direction of movement and location of plants 2

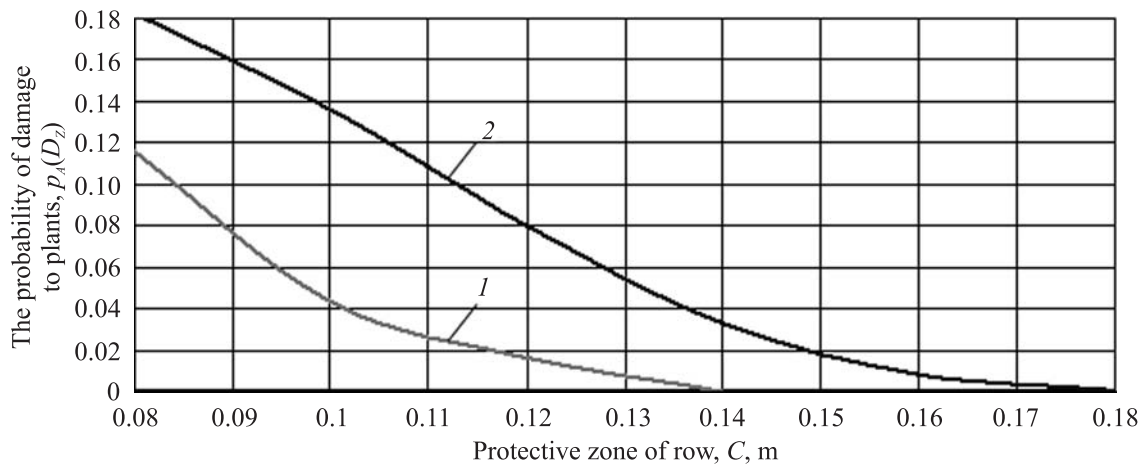

**Fig. 6.** The probability of damaging the plants  $\delta_A(D_Z)$  depending on the scope of the protection zone  $\tilde{N}$ : 1 – internal working tool; 2 – external working tool

tection zone of 13 cm the probability of damage, done with the external working tool is 5.5 %, and with the internal one – 1%. It is obvious that the difference in damaging the plants is significant.

The abovementioned may be used to make a conclusion that both working tools of the wide-span tractor, located on both sides of the row, should be placed at the uneven distance from the axis of the row. In our case, with damage to plants up to 1%, the protection zone of the rows, processed with the farthest working tools should be 13 and 16 cm respectively.

### CONCLUSIONS

The mathematical methods of determining kinematic parameters of wide-span tractors and the probability

of damaging plants in a row, which provide for substantiated selection of distances between the kinematic center of the tractor and the center of resistance of the device, used for controlled traffic and the working tools as well as for selection of the scope of the protection zone with the consideration of their constructive parameters, stability and movement controllability, were suggested.

New mathematical dependences were elaborated, the application of which allows determining permissible thresholds of transversal displacements of the working tools, remarkable for standard deviation in agrotechnical conditions regarding the damage to plants in a row, which takes place while estimating the working indices of wide-span tractors in the controlled traffic farming.



The factor of displacement difference should be taken into consideration while placing the cultivator working tools for wide-span tractors. The scope of the protection zone for the working tools, located externally from the geometrical axis of the row and the center of the tractor should be larger than that for the internal ones on condition of even damage to plants in the row (approximately for 3 cm).

The value of internal and external deviations of the working tools as well as the absolute difference in average deviation is considerably dependent on their longitudinal and transversal locations regarding the center of the wide-span tractor and is defined by the value of its angular deviation from the given direction of movement. In case of small value of the given parameters, the value of deviations and the absolute difference in their average shift is insignificant. The automatization of managing the movement of the wide-span tractor with the purpose of decreasing the combination of all its angular deviations from the given direction of movement will allow reducing the probability of cutting the plants in a row with working tools, especially the farthest ones.

It was determined that from the kinematic standpoint the optimal zone of placing the tools for controlled traffic and working tools is concentrated at a minimally possible longitudinal distance from the kinematic center of the tractor. If the tools of controlled traffic are placed further from the kinematic center of the tractor, there should be rigid fixing. The working tools should have flexible fixing here, and be placed from the resistance center at a minimally possible distance from the center of resistance of the tools of controlled traffic. The optimal longitudinal distance from the kinematic center of the tractor to the tracking point for the movement trajectory is 3–4 m.

#### **Математичне моделювання рухів робочих органів агрозасобу в колійній системі землеробства**

В.В. Адамчук, В.М. Булгаков, І.В. Головач, В.П. Кувачов  
e-mail: nnc-imesg@ukr.net: vbulgakov@meta.ua

<sup>1</sup> Національний науковий центр “Інститут механізації і електрифікації сільського господарства” НААН України  
Вул. Вокзальна, 11, Глеваха-1, Васильківський р-н,  
Київська обл., Україна, 08631

<sup>2</sup> Національний університет біоресурсів і природокористування України  
Вул. Героїв Оборони, 15, Київ, Україна, 03041

<sup>3</sup> Таврійський державний агротехнологічний університет  
Пр. Б. Хмельницького, 18, Мелітополь,  
Запорізька обл., Україна, 72310

Головний показник якості роботи ширококоліїних агрозасобів для колійної системи землеробства – величина

пошкоджуваності рослин робочими органами. Пошкоджуваність рослин багато в чому залежить від величини поперекових зміщень робочих органів, що обумовлено стійкістю руху ширококоліїного агрозасобу і певною розбіжністю траєкторії сформованої постійної технологічної колії і робочих органів в площині поля. Таким чином, вивчення поперекового руху робочих органів ширококоліїного агрозасобу та вплив його коливань на якість виконання технологічного процесу вимагають глибшого дослідження й обґрунтування конструктивних і кінематичних параметрів, що забезпечить високу якість їх роботи в колійній системі землеробства. **Мета.** Підвищення якості роботи ширококоліїних агрозасобів, завдяки розробленню математичної моделі поперекових зміщень робочих органів, дозволить обґрунтувати конструктивно-кінематичні параметри, а також величину захисної зони, за умов відсутності пошкоджуваності рослин. **Методи.** Застосовано методи побудови розрахункових математичних моделей функціонування сільськогосподарських машин і машинних агрегатів на основі теоретичної механіки, вищої математики та теорії імовірності. **Результати.** Запропоновані методи визначення кінематичних параметрів ширококоліїних агрозасобів і імовірності пошкодження рослин у рядку, які дозволяють обґрунтовано обирати відстані між кінематичним центром агрозасобу і центром опору знаряддя для прокладання постійної технологічної колії і робочих органів, а також обирати величину захисної зони з урахуванням їх конструктивних параметрів, стійкості і керованості руху. Розроблено нові математичні залежності, використання яких дозволяє визначати допустимі межі поперекових зміщень робочих органів, які характеризуються середньоквадратичним відхиленням агротехнічних умов щодо пошкоджуваності рослин у рядку, що має місце при оцінці показників роботи ширококоліїних агрозасобів в колійній системі землеробства. **Висновки.** Оптимальна зона розміщення знаряддя для прокладання постійної технологічної колії і робочих органів зосереджена на мінімально можливій величині прямої відстані від кінематичного центра агрозасобу. При розстановці робочих органів для ширококоліїних агрозасобів слід враховувати фактор різниці їх зміщень.

**Ключові слова:** колійна система землеробства, ширококоліїний агрозасіб, пошкоджуваність рослин, поперекові зміщення.

#### **Математическое моделирование движений рабочих органов агроприспособления при колёйной системе земледелия**

В.В. Адамчук, В.М. Булгаков, И.В. Головач, В.П. Кувачов  
e-mail: nnc-imesg@ukr.net: vbulgakov@meta.ua

<sup>1</sup> Национальный научный центр "Институт механизации и электрификации сельского хозяйства"  
НААН Украины

Ул. Вокзальная, 11, Глеваха-1, Васильковский р-н,  
Киевская обл., Украина, 08631

<sup>2</sup> Национальный университет биоресурсов  
и природопользования Украины  
Ул. Героев Обороны, 15, Киев, Украина, 030413  
Таврийский государственный  
агротехнологический университет  
Пр. Б. Хмельницкого, 18, Мелитополь,  
Запорожская обл., Украина, 72310

Главный показатель качества работы ширококолейных агроприспособлений для путевой системы земледелия – величина повреждаемости растений рабочими органами. Повреждаемость растений во многом зависит от величины поперечных смещений рабочих органов, что обусловлено устойчивостью движения ширококолейного агроприспособления и определенным расхождением траектории сложившейся постоянной технологической колеи и рабочих органов в плоскости поля. Таким образом, изучение поперечного движения рабочих органов ширококолейного агроприспособления и влияние их колебаний на качество выполнения технологического процесса требуют более глубокого исследования и обоснования конструктивных и кинематических параметров, что обеспечит высокое качество их работы в путевой системе земледелия. **Цель.** Повышение качества работы ширококолейных агроприспособлений, благодаря разработке математической модели поперечных смещений рабочих органов, позволит обосновать конструктивно-кинематические параметры, а также величину защитной зоны при отсутствии повреждаемости растений. **Методы.** Применены методы построения расчетных математических моделей функционирования сельскохозяйственных машин и машинных агрегатов на основе теоретической механики, высшей математики и теории вероятности. **Результаты.** Предложенные методы определения кинематических параметров ширококолейных агроприспособлений и вероятности повреждения растений в колее, которые позволяют обоснованно выбирать расстояния между кинематической центром агроприспособления и центром сопротивления орудия для прокладки постоянной технологической колеи и рабочих органов, а также выбирать величину защитной зоны с учетом их конструктивных параметров, устойчивости и управляемости движения. Разработаны новые математические зависимости, использование которых позволяет определять допустимые пределы поперечных смещений рабочих органов, характеризующихся среднеквадратичным отклонением агротехнических условий по повреждаемости растений в колее, которое имеет место при оценке показателей работы ширококолейных агроприспособлений в путевой системе земледелия. **Выводы.** Оптимальная зона размещения орудия для прокладки постоянной технологической колеи и рабочих органов сосредоточена на минимально возможной величине прямой расстояния от кинематического центра агроприспособления. При расстановке рабочих органов для ширококолейных агроприспособлений следует учитывать фактор разницы их смещений.

**Ключевые слова:** путевая система земледелия, ширококолейное агроприспособление, повреждаемость растений, поперечные смещения

#### REFERENCES

1. *Chamen T.* Controlled traffic farming – from worldwide research to adoption in Europe and its future prospects. *Acta Technologica Agriculturae*. 2015;**18**(3):64–73.
2. *Onal I.* Controlled Traffic farming and Wide Span Tractors. *Journal of Agricultural Machinery Science*. 2012; **8**(4):353–64.
3. *Gasso V, Sørensen CAG, Oudshoorn FW, Green O.* Controlled traffic farming: A review of the environmental impacts. *European Journal of Agronomy*. 2013;**48**:66–73.
4. *Pedersen HH, Sørensen CG, Oudshoorn FW.* User requirements for a Span Tractor for Controlled Traffic Farming. *International Commission of Agricultural and Biological Engineers, Section V. CIOSTA XXXV Conference “From Effective to Intelligent Agriculture and Forestry”*. Denmark, 3–5 July 2013.
5. *Chamen WCT, Dowler D, Leede PR, Longstaff DJ.* Design, Operation and Performance of a Gantry System: Experience in Arable Cropping. *Journal of Agricultural Engineering Research*. 1994;**59**(1):45–60.
6. *Chamen WCT.* A New Methodology for Weed Control And Cereal Crop Production Based On Wide Span Vehicles And Precision Guidance. *4th EWRS Workshop on Physical Weed Control*. The Netherlands. 20–22 March 2000: 51–55.
7. *Nadykto V.T., Ayubov A.M., Kovalenko A.V.* The study of the device of controlled traffic farming. *The works of TDATA*. 2005;is.30:3–11.
8. *Kuvachov V.* The study wide span tractor (vehicles) for controlled traffic farming. *Mechanization in agriculture & Conserving of the resources*. Sofia, Bulgaria. 2017;(1): 15–17.
9. *Kuvachov V.* Simulation of flat-parallel movement of a wide-span tractor in the horizontal field with the kinematic way of its management. *Motrol*. 2015;**17**(9):49–54.
10. *Kuvachov V.P.* Estimation of movement stability of wide-span energotechnological mechanization devices of agricultural production. *The works of TDATU*. 2015; Is. 15,**3**: 204–210.
11. *Nadykto VT, Kuvachov VP.* Estimation of movement management of wide-span energotechnological mechanization devices of agricultural production. *Scientific bulletin of TDATU*. 2016; Is. 6.,**1**:99–110.
12. *Baev IV.* Optimization of kinematic parameters of ag-gregation and movement of three-machine semi-mount-ed sowing and row-crop machine-tractor aggregates. *Mechanization and electrification of agriculture*. 1982; Is.55:54–59.
13. *Gatti PL.* Probability theory and mathematical statistics for engineers. 2005;356 p.
14. *Mitropolsky AK.* Technology of statistical processing. *Moscow, Nauka*. 1971;576 p.
15. *Khachatryan Kh.A.* Work stability of tillage aggregates. *Moscow, Mashinostroenie*. 1974;206 p.