

Theory of motion of grain mixture particle in the process of aspiration separation

V. Bulgakov¹, S. Nikolaenko¹, I. Holovach¹, A. Boris², S. Kiurchev³,
Ye. Ihnatiev³ and J. Olt^{4,*}

¹National University of Life and Environmental Sciences of Ukraine, 15 Heroyiv Oborony Str., UA 03041 Kyiv, Ukraine

²National Scientific Centre, Institute for Agricultural Engineering and Electrification, 11, Vokzalna Str., Glevakcha – 1, Vasylkiv District, UA08631, Kiev Region, Ukraine

³Dmytro Motornyi Tavria State Agrotechnological University, 18^B, Khmelnytsky Ave, UA 72310, Melitopol, Zaporozhye Region, Ukraine,

⁴Estonian University of Life Sciences, Institute of Technology, 56 Kreutzwaldi Str., EE51006 Tartu, Estonia

*Correspondence: jyri.olt@emu.ee

Abstract. The paper describes the development of a mathematical model for the motion of a seed mixture particle in the aspiration channel of the separator after the particle passes the cone-shaped spreader and enters the workspace of the aspiration channel in the pneumatic dynamics and vibration unit devised by the authors. The unique feature of the proposed new design is the presence of the central pipe with sail members in the aspiration channel. The sail members in the air stream generate the self-oscillatory mode of motion of the central pipe, which results in the efficient separation of the grain seed mixture into the required fractions. On the basis of the prepared equivalent schematic model, the differential equations of the motion of a seed mixture particle in the process of aspiration separation have been generated. Basing on the results of the PC-assisted numerical modelling of the motion paths, on which the material particles (seeds) of the heavy and medium fractions travel, it has been established that they move on different courses, and the course of the heavy fraction seeds is such that, after they pass the cone-shaped spreader and advance further in the air stream through the space of the aspiration channel, they move closer to the pipe of the aspiration channel. Also, their velocities and accelerations are greater than the same kinematic parameters of the medium fraction seeds. The seeds of the light fraction move upwards under the action of the air stream and leave the aspiration separator at its top.

Key words: air flow, aspiration channel, grain seed mixture, material particle, separation.

INTRODUCTION

The necessary condition for the reliable storage of grain and seeds of various crops is the high quality of their postharvest handling, including the cleaning of the grain and seeds from the impurities that accompany them after the harvesting as well as the division of the heap into the required fractions. It should be noted that the separation of grain and seeds and their division into fractions in the state-of-the-art seed-cleaning machines is often done with the use of air flows. Also, this process is performed in

aspiration channels of various designs, which, according to the data of experimental investigations that have been conducted, feature a number of shortcomings.

The original design for the aspiration channels did not ensure the uniform feeding of bulk grain inside the channel. Due to their intrinsic properties, the seeds of various forms of grain were difficult to separate into fractions using this design. Yields were negligible, so the separation of seed mixtures using these separators was mainly ineffective. Attempts to make aspiration channels of larger diameters also failed to solve the problem because, in that particular case, significant power was required to create the air flow for suction. In addition to this significant increase in power requirements for the process, fluctuations and losses of air pressure began to occur. That is why the use of such separators for ordinary seed mixtures was ineffective. Subsequently, the aspiration separation method was used only when separating seed material for planting and then only where the seeds as separate entities have better aerodynamic qualities, a higher sail factor, and so on. The shortcomings in the use of aspiration separators in separating such types of bulk grain also include a lack of precise separation of the seeds into fractions and the lack of their effective transportation out of the separation zone.

After the thorough analysis of numerous scientific papers (Panasiewicz, 1999; Panasiewicz et al., 2012; Kharchenko et al., 2017; Stepanenko, 2017; Khamyev et al., 2018; Badretidinov et al., 2019) on the topic of separating grain and seeds of various crops, the authors have come to a conclusion that the highest quality of the separation process is achieved in a vertical aspiration channel with the division of the fractions taking place at its bottom. In this case, high performance can be achieved in the classification of free-flowing dry masses and the possibility of effectively handling multiple-fraction mixtures is implemented.

In order to justify the rational design and kinematic parameters of the grain mixture separator devised by the authors, it is necessary to carry out a number of theoretical investigations, in particular, to develop the theory of motion of a grain mixture particle during aspiration separation.

The scientific research into the process of separating grain and grain crop seeds is represented in the papers (Proturayev & Franchuk, 1970; Burkov 1991; Kotov, 2002; Brăcăcescu et al., 2012; Kyurchev & Kolodiy, 2012; Kroulik et al., 2016; Brăcăcescu et al., 2019) The theoretical basis for the improvement of the process of the vibration separation of dry loose masses has been laid in the papers (Kotov, 2002; Saitov et al., 2016 and 2018; Bedretidinov et al., 2019), in which the process of pneumatic separation in the vertical version of the apparatus is investigated with the use of the principles of the nonlinear dynamics of biphasic media and also the said process is studied with the use of the equation of the seed's motion in an aerodynamic medium (Leshchenko et al., 2009; Kyurchev & Kolodiy, 2015).

The further studies on the said process have proved that the directional flow of air acts on the motion path of the particle (seed) mostly at the moment of its movement from the internal wall to the external one: in the central part of the aspiration channel the velocity of the air is maximal, while near the walls it is reduced, which is detrimental to the separation conditions (Bernik & Palamarchuk, 1996; Vasilkovsky et al., 2007). At the same time, the lower zone of the air stream is not used as a seed material separation factor, although the different soaring velocities of the grain fractions in this section of the separator provide a possibility of obtaining an additional effect of the improved sharpness of separation.

In view of the above-said, this paper presents a theoretical study on the process of the seed material separation in a vertical aspiration channel with bottom discharge, where the self-oscillatory motion of the separator's central pipe is generated in order to separate with high quality the motion paths of different fractions of the seed material.

The aim of the study is to improve the throughput capacity and the quality of loose grain mixture separation by means of theoretically substantiating the rational parameters of the aspiration seed separator.

MATERIALS AND METHODS

Based on the foregoing, some considerable changes can be made in the technological process that is involved in aspiration separation, making it possible to increase its effectiveness. The authors have developed a new design of the seed separator for grain and oil crops, in which the aspiration separation with the bottom separation of fractions is performed. The design and process schematic model of the separator is presented in Fig. 1 a, while Fig. 1 b provides the general view of the separator (Bulgakov et al., 2020).

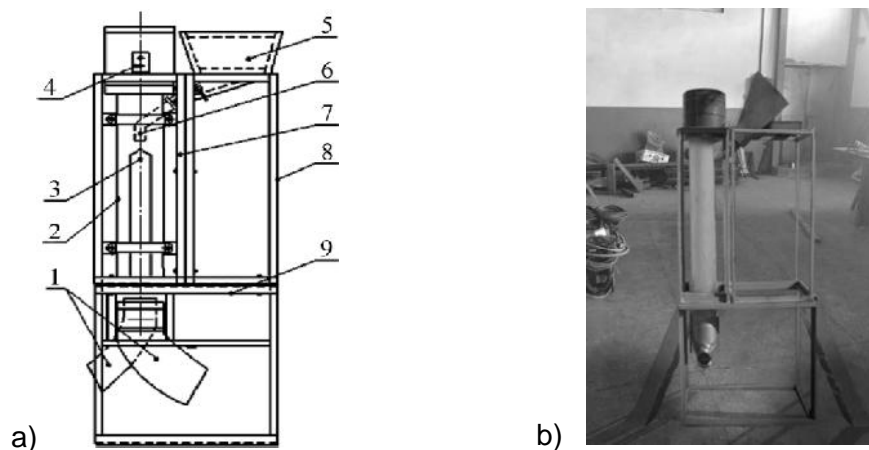

Figure 1. Aspiration seed separator: a – design and process schematic model: 1 – receiving bins for separated seeds, 2 – aspiration channel, 3 – cone-shaped seed spreader, 4 – fan, 5 – grain mixture hopper, 6 – feeding pipe, 7 – aspiration channel mounting frame, 8 – main frame, 9 – frame base plate; b – general view.

The primary operating device of the proposed vibration and aspiration separator is the aspiration channel 2 with a central pipe inside it. The top of the central pipe is equipped with the seed spreader 3. The aspiration channel 2 is mounted in the centre of the frame 7 contained inside the main frame 8. In the upper part of the separator, the fan 4 that induces the flow of air is installed. The air is sucked in at the bottom and moves upwards. Also, on top of the main frame 8, the grain mixture hopper 5 is situated, from which the mixture of seeds moves along the feeding pipe 6. In its bottom part, the main frame 8 contains the base plate 9, to which the receiving bins 1 for separated seeds are attached. The receiving bins 1 have two arched channels for discharging the seeds of the medium and heavy fractions in different directions.

The pneumatic and gravity separator operates as follows. In the process of separation, the grain mixture moves from the hopper 5 via the feeding pipe 6 mounted with a slope in order to facilitate the sliding of the seeds from the hopper 5 to the upper part of the central pipe of the aspiration channel 2. In this way, the grain mixture flows from above to the central pipe of the vertical aspiration channel 2 directly onto the cone-shaped seed spreader 3. The seeds of grain or oil crops are uniformly distributed by the spreader 3 on the radial directions of the cone, move downwards and, at the base of the cone, slip off, leaving the spreader 3, and enter the ring-shaped internal space around the central pipe of the aspiration channel 2. The exhaust fan 4 generates the air updraft, which splits the oncoming mass of seeds into different motion paths depending on their specific gravity. Lighter seeds (and light impurities) are entrained by the air and move upwards, while the seeds in the medium and heavy fractions sink downwards. In their sinking, the medium fraction seeds slightly change their course and arrive into one of the receiving bins 1, while the heaviest fraction seeds fall along such lines of motion that allow them to concentrate around the central pipe of the aspiration channel 2 most closely to its surface.

The shortcomings of the above pneumatic and gravity seed separator include its low throughput capacity, which is due to the absence of any means for intensifying the movement of seeds inside the aspiration channel 2 in order to facilitate the faster advancement of the already separated seeds towards the bottom under the action of external forces.

The vibration and pneumatic dynamics separator with a movable central pipe contained in the vertical aspiration channel represented by a fixed pipe of greater diameter, in which the central pipe is connected to the fixed pipe with elastic members, is an improved version of the above design. The movable pipe is equipped with sail members, which make the pipe perform self-oscillations under the action of the air flow in the aspiration channel and that, in its turn, results in the efficient separation of the grain seed mixture into the required fractions.

The initial stage of the theoretical investigation is the analysis of the seed's motion dynamics after its departure from the cone-shaped seed spreader. The following assumptions have been admitted in the mathematical modelling of the separation processes in the above-mentioned section of the separator:

- seed material is fed into the vertical air flow that is uniformly distributed throughout the internal space of the aspiration channel at an initial angle of α_0 and an initial velocity of V_0 ;

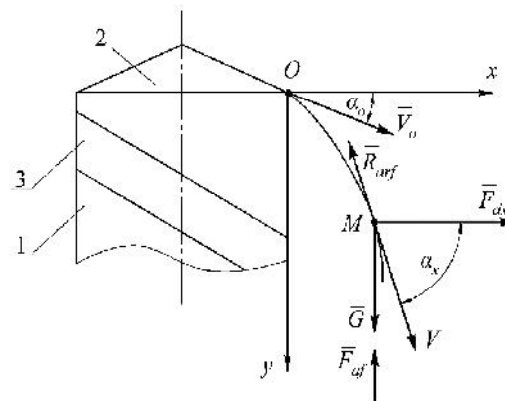

Figure 2. Equivalent schematic model of motion of material particle (seed) after its departure from cone-shaped seed spreader: 1 – separator central pipe; 2 – cone-shaped seed spreader; 3 – sail member.

- it is assumed that the case under consideration involves the motion of isolated seeds (material particles), the sizes and masses of which determine their soaring velocity;
- seeds do not change their symmetry axis alignments with respect to the direction of the air flow;
- air flow has a vertical upward direction.

The first step is to generate an equivalent schematic model of the material particle's (seed's) motion after its departure from the cone-shaped seed spreader. Such a schematic model is presented in Fig. 2.

The presented schematic model features the forces acting on the material particle (grain seed). These forces include, first of all: \bar{F}_{af} – force applied by the air flow, \bar{F}_{dx} – perturbing force component generated by the self-oscillatory motion of the separator's central pipe equipped with sail members.

SEPARATING PROCESS MODEL

In the previously completed research (Kotov, 2002), it has been proved that the force F_{dx} can be determined with the use of the following expression:

$$F_{dx} = \frac{l_x \cdot F_{af} \cdot \sin \omega t}{\sqrt{2} \cdot l}, \quad (1)$$

where l_x – displacement of the centre of the separator central pipe cross-section from the vertical axis; ω – angular velocity of the rotation of the separator central pipe during its self-oscillations with respect to the vertical axis; l – maximum possible displacement of the separator central pipe cross-section from the vertical axis; t – arbitrary instant of time.

Further, the expression has to be written down for the air resistance force \bar{R}_{arf} that acts during the motion of the seed particle in the air flow. Subject to the air flow velocity staying at a sufficiently moderate level, that is, below or at 8.0 m s^{-1} , the force under consideration can be determined with the use of the following well-known expression:

$$R_{arf} = \xi \cdot S_m \cdot \frac{V^2}{2} \cdot \rho, \quad (2)$$

where S_m – area of the midsection of the particle; ξ – medium resistance factor: for an ellipsoid shape of the seed $\xi = 0.04$; ρ – air density; V – velocity of the particle in the air flow.

It must be noted that, upon entering the air space of an aspiration channel, and after leaving the cone-shaped seed spreader, a material particle (a seed) starts its journey at a speed of V_o in a counter-flowing air current and, as a result, its movement speed V starts to decrease. The direction of the velocity vector \bar{V} of the material particle (seed) motion in the air space of the aspiration channel is defined by the angle a_x between the vector under consideration \bar{V} and the Ox axis.

As is known, the force vector \bar{R}_{arf} has a line of action opposite to the direction of the velocity vector \bar{V} .

The material particle (seed) is also under the action of the particle weight force \bar{G} which, as is known, has the following magnitude:

$$G = mg, \quad (3)$$

where m – mass of the particle; g – acceleration of gravity.

The next step is to analyse the motion of the particle (seed) in the absolute coordinate system Oxy , the origin of which (point O) is situated at the place, where the material particle (seed) leaves the cone-shaped seed spreader and enters the stream of air, the Ox axis is directed horizontally to the right, the Oy axis – vertically downwards.

In accordance with the schematic model of forces presented in Fig. 1 and on the basis of Newton's second law, a system of differential equations can be generated, which will represent the motion of the material particle (seed) in the air flow after its departure from the cone-shaped seed spreader in the projections on the Ox and Oy coordinate axes:

$$\left. \begin{aligned} m\ddot{x} &= -R_{arf} \cdot \cos \alpha_x + F_{dx}, \\ m\ddot{y} &= -R_{arf} \cdot \sin \alpha_x - F_{af} + G, \end{aligned} \right\} \quad (4)$$

where m – mass of the particle, \ddot{x} , \ddot{y} – components of the particle's acceleration along the Ox and Oy axes, respectively.

In view of the fact that:

$$V^2 = \dot{x}^2 + \dot{y}^2, \quad (5)$$

and

$$\cos \alpha_x = \frac{\dot{x}}{V} = \frac{\dot{x}}{\sqrt{\dot{x}^2 + \dot{y}^2}}, \quad (6)$$

$$\sin \alpha_x = \frac{\dot{y}}{V} = \frac{\dot{y}}{\sqrt{\dot{x}^2 + \dot{y}^2}}, \quad (7)$$

and taking into account the expression (2), the following is arrived at:

$$R_{arf} \cdot \cos \alpha_x = \xi \cdot S_M \cdot \rho \cdot \frac{(\dot{x}^2 + \dot{y}^2)}{2} \cdot \frac{\dot{x}}{\sqrt{\dot{x}^2 + \dot{y}^2}}, \quad (8)$$

or

$$R_{arf} \cdot \cos \alpha_x = \frac{1}{2} \xi \cdot S_M \cdot \rho \cdot \sqrt{\dot{x}^2 + \dot{y}^2} \cdot \dot{x} \quad (9)$$

Similarly, the following is obtained:

$$R_{arf} \cdot \sin \alpha_x = \frac{1}{2} \xi \cdot S_M \cdot \rho \cdot \sqrt{\dot{x}^2 + \dot{y}^2} \cdot \dot{y}, \quad (10)$$

After the expressions (1), (3), (9) and (10) are substituted into the system of differential equations (4) and both sides of the equations are divided by the particle's mass m , the result is:

$$\left. \begin{aligned} \ddot{x} &= \frac{l_x \cdot F_{af} \cdot \sin \omega t}{\sqrt{2} \cdot m \cdot l} - \frac{1}{2m} \xi \cdot S_M \cdot \rho \cdot \sqrt{\dot{x}^2 + \dot{y}^2} \cdot \dot{x}, \\ \ddot{y} &= -\frac{F_{af}}{m} + g - \frac{1}{2m} \xi \cdot S_M \cdot \rho \cdot \sqrt{\dot{x}^2 + \dot{y}^2} \cdot \dot{y}. \end{aligned} \right\} \quad (11)$$

In order to simplify the writing of the system of differential Eqs (11), the following designations are introduced:

$$B_1 = \frac{\xi \cdot S_M \cdot \rho}{2}, \quad B_2 = \frac{l_x \cdot F_{af}}{\sqrt{2} \cdot l}. \quad (12)$$

By substituting the expressions (12) into the system of differential Eqs (11), the following is obtained:

$$\left. \begin{aligned} \ddot{x} + \frac{B_1}{m} \cdot \sqrt{\dot{x}^2 + \dot{y}^2} \cdot \dot{x} &= \frac{B_2}{m} \sin \omega t, \\ \ddot{y} + \frac{B_1}{m} \cdot \sqrt{\dot{x}^2 + \dot{y}^2} \cdot \dot{y} &= g - \frac{F_{af}}{m}. \end{aligned} \right\} \quad (13)$$

The system of differential Eqs (13) is a system of nonlinear differential equations of second order, which, as is known, cannot be solved by quadrature. It can only be solved with the use of numerical methods (for example, the Runge-Kutta method), by operating the PC in the MathCAD problem-solving environment. The numerical solving provides a result in the form of the graphical relations between the motion of the particle along the axes Ox and Oy and the time t .

The system of Eqs (13) has to be solved under the following initial conditions: at $t = 0$:

$$\dot{x}_0 = V_0 \cdot \cos \alpha_0, \quad \dot{y}_0 = V_0 \cdot \sin \alpha_0, \quad x_0 = 0, \quad y_0 = 0. \quad (14)$$

The initial movement speed V_0 of a material particle (seed) is determined by its speed of movement along the side of the cone-shaped spreader, which is where it immediately ends up. Therefore, while moving along the cone-shaped spreader's side, the particle is not influenced by anything at all because the entering air flow does not affect it (the particle). But, immediately after the particle leaves the cone-shaped spreader and even under the conditions of a negligible deviation from the central pipe, the vector of the particle's initial speed \vec{V}_0 is strictly parallel to the cone's side and has a deviation from the horizontal plane at an angle of α_0 . Upon any further movement taking place, the particle acquires the speed V as stated above. In projections to the accepted coordinate axes, the value of the initial speed is determined from expressions (14).

However, by using the experimental data, the system of differential Eqs (13) can be reduced to the linear form and solved by quadrature. That will result in obtaining the analytical solution that is sufficient for practical purposes.

On the basis of experimental investigations, the following has been arrived at:

$$V_x = \dot{x} = (0.15 \dots 0.20) \text{ m} \cdot \text{s}^{-1},$$

$$V_y = \dot{y} = (0.70 \dots 0.80) \text{ m} \cdot \text{s}^{-1}.$$

Then:

$$\begin{aligned} V &= \sqrt{0.15^2 + 0.70^2} \dots \sqrt{0.20^2 + 0.80^2} = \sqrt{0.513} \dots \sqrt{0.680} = \\ &= (0.72 \dots 0.82) \text{ m} \cdot \text{s}^{-1}. \end{aligned}$$

The next step is to substitute the left (minimal) values of the intervals obtained for \dot{x} , \dot{y} and V into the system of equations (13), then to do the same with the right (maximal) values and, by solving the generated systems of equations by quadrature, the respective value ranges are obtained for the displacements of the particle along the Ox axis and the Oy axis.

Consequently, assuming that $\dot{x} = V_x = \text{const}$, $\dot{y} = V_y = \text{const}$ and $V = \text{const}$, the following system of equations is obtained instead of the system (13):

$$\left. \begin{aligned} \ddot{x} &= -\frac{B_1}{m} \cdot V \cdot V_x + \frac{B_2}{m} \sin \omega t, \\ \ddot{y} &= -\frac{B_1}{m} \cdot V \cdot V_y + g - \frac{F_{af}}{m}. \end{aligned} \right\} \quad (15)$$

The result of the first integration is:

$$\left. \begin{aligned} \dot{x} &= -\frac{B_1}{m} \cdot V \cdot V_x \cdot t - \frac{B_2}{m \cdot \omega} \cos \omega t + C_1, \\ \dot{y} &= \left(-\frac{B_1}{m} \cdot V \cdot V_y + g - \frac{F_{af}}{m} \right) \cdot t + L_1, \end{aligned} \right\} \quad (16)$$

where C_1 and L_1 – arbitrary constants.

The result of the second integration is:

$$\left. \begin{aligned} x &= -\frac{B_1}{2m} \cdot V \cdot V_x \cdot t^2 - \frac{B_2}{m \cdot \omega^2} \sin \omega t + C_1 \cdot t + C_2, \\ y &= \left(-\frac{B_1}{m} \cdot V \cdot V_y + g - \frac{F_{af}}{m} \right) \cdot \frac{t^2}{2} + L_1 \cdot t + L_2, \end{aligned} \right\} \quad (17)$$

where C_2 and L_2 – arbitrary constants.

Therefore the authors have rendered the nonlinear system of differential equations into a more simple scheme of differential equations (15) with constant coefficients. The solution for the system (15) - the first integral (16) and the second integral (17) - made it possible to undertake the necessary transformations and to achieve simple equations, describing with sufficient precision the movement of a material particle (seed) under the influence of the forces being applied to it inside the aspiration channel.

The above arbitrary constants can be found using the initial conditions (14):

$$C_1 = V_o \cos \alpha_o + \frac{B_2}{m \cdot \omega}, \quad L_1 = V_o \cdot \sin \alpha_o, \quad C_2 = 0 \quad \text{and} \quad L_2 = 0. \quad (18)$$

After (18) is substituted into (16), the following is obtained:

$$\left. \begin{aligned} \dot{x} &= -\frac{B_1}{m} \cdot V \cdot V_x \cdot t - \frac{B_2}{m \cdot \omega} \cos \omega t + V_o \cdot \cos \alpha_o + \frac{B_2}{m \cdot \omega}, \\ \dot{y} &= \left(-\frac{B_1}{m} \cdot V \cdot V_y + g - \frac{F_{af}}{m} \right) \cdot t + V_o \cdot \sin \alpha_o. \end{aligned} \right\} \quad (19)$$

The result of substituting (18) into (17) is:

$$\left. \begin{aligned} x &= -\frac{B_1}{2m} \cdot V \cdot V_x \cdot t^2 - \frac{B_2}{m \cdot \omega^2} \sin \omega t + \\ &+ \left(V_o \cdot \cos \alpha_o + \frac{B_2}{m \cdot \omega} \right) \cdot t, \\ y &= \left(-\frac{B_1}{m} \cdot V \cdot V_y + g - \frac{F_{af}}{m} \right) \cdot \frac{t^2}{2} + V_o \cdot \sin \alpha_o \cdot t. \end{aligned} \right\} \quad (20)$$

The systems of Eqs (19) and (20) represent the laws of variation for the velocity and the displacement of the material particle (seed), respectively, as functions of time with due account for the design, kinematic and dynamic parameters of the aspiration separator.

This way, the transformations that have been carried out made it possible to reach systems that involved differential Eqs, (19) and (20), which are the most suitable equations for solving the problem digitally, on a PC.

In order to carry out the PC-assisted numerical calculations, it is necessary to define the initial and boundary conditions. For example, the initial velocity V_o of the motion of the material particle (seed) at the instant of its departure from the surface of the cone-shaped seed spreading unit was determined by the authors on the basis of the experimental data for various types of seeds and was found to be within the range of $V_o = 0.70\text{--}0.80 \text{ m s}^{-1}$. For the numerical calculation purposes, it is assumed that $V_o = 0.75 \text{ m s}^{-1}$.

This initial speed value was determined by the authors for individual sunflower seeds after decoding the video recording of the seed's movement along the side of the cone-shaped spreader and processing it using the appropriate software on a PC. The initial deflection angle of the initial velocity vector V_o , that describes the motion of the material particle (seed) at the instant, when it leaves the surface of the cone-shaped seed spreader, is taken to be equal to $\alpha_o = 20^\circ$. This angle is exactly determined by the factual dimensions of the cone-shaped seed spreader that was used by the authors, ie. the angle α_o is determined by the inclination angle of the side of the cone-shaped seed spreader to the horizon.

Further, the force generated by the air stream F_{af} is to be determined. Basing on the air compressor power rating N , the force generated by the air stream F_{af} is equal to:

$$F_{af} = \frac{N}{V_{af}} \quad (21)$$

where $V_{af} = (4.5\text{--}5.5) \text{ m s}^{-1}$ – velocity of the air flow, which is taken to be equal to $V_{af} = 5.0 \text{ m s}^{-1}$ for the calculation purposes; $N = 150.0 \text{ W}$.

Hence, the air flow force value equal to $F_{af} = 30.0 \text{ N}$ is assumed for the numerical calculations.

The angular velocity ω of the aspiration separator pipe rotation, which is determined with the use of the expression $\omega = V_{af} \cdot (r_D)^{-1}$, under the condition that the pipe radius r_d is equal to 0.10 m, has the following magnitude: $\omega = 50.0 \text{ s}^{-1}$. The other parameters used in the numerical calculations are assigned the following values: $m = 0.068 \text{ g}$ – mass of the material particle (seed); $L_x = 0.010 \text{ m}$; $l = 0.020 \text{ m}$ – linear displacements of the central pipe of the aspiration separator.

RESULTS AND DISCUSSION

Basing on the analytic expressions (19) and (20), PC-assisted numerical calculations have been carried out and the graphical relations have been obtained for the material particle (seed) motion paths, the velocity and acceleration of the particle (seed) as functions of time t at specific values of the design, kinematic and dynamic parameters of the aspiration grain heap separator. When carrying out the PC-assisted numerical

calculations, the following values were assumed by the authors for the mass of a single grain crop seed: 0.020 grams in the light fraction; 0.040 grams in the medium fraction; 0.080 grams in the heavy fraction. These single grain crop seed masses are the most effectively-separated fractions when using the aspiration separator that has been developed by the authors. The above-mentioned graphical relations are presented in Fig. 3–6.

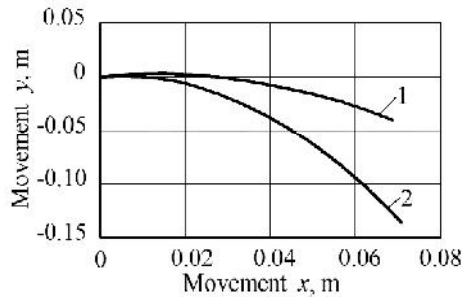

Figure 3. Material particle (seed) motion path in plane Oxy : 1 – medium fraction seeds; 2 – heavy fraction seeds.

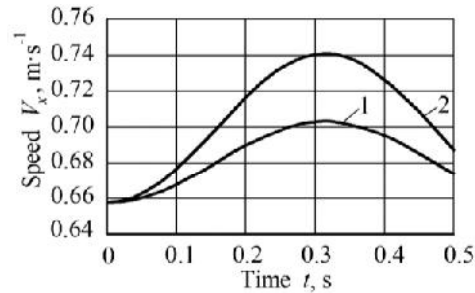

Figure 4. Variation of material particle (seed) velocity V_x as function of t relative to Ox axis: 1 – medium fraction seeds; 2 – heavy fraction seeds.

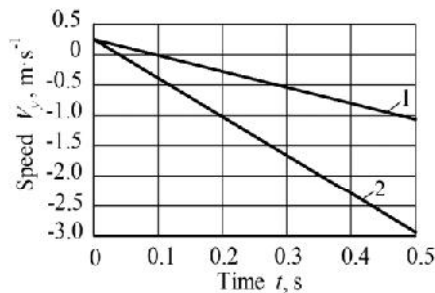

Figure 5. Variation of material particle (seed) velocity V_y as function of t relative to Oy axis: 1 – medium fraction seeds; 2 – heavy fraction seeds.

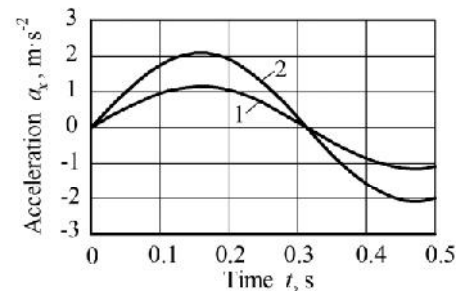

Figure 6. Variation of material particle (seed) acceleration α_x as function of t relative to Ox axis: 1 – medium fraction seeds; 2 – heavy fraction seeds.

As is obvious from the presented graphs, the motion path of the material particle (seed), the diagram of which is shown in Fig. 3a, has such a curvilinear shape that the heavy fraction seeds virtually do not translate along the x axis, but concentrate in their downward movement close to the central pipe of the aspiration channel. Moreover, within the time interval under consideration, the increase of the values of the y coordinate is accompanied by only insignificant variation of the x coordinate for both the masses. The projections of the velocities on the respective coordinate axes x and y also demonstrate different behaviours (Figs 4 and 5). For example, at the initial instant of the departure of the particle (seed) from the cone of the seed spreader, the variation of the particle's motion along the y axis is slow, while the variation of the velocity projection on the x axis is more intensive. The pattern of variation followed by the acceleration of

the particle (seed), as shown in Fig. 6, is similar to that followed by the velocity projection on the same axis x . After that, the process of the free fall of the material particle (seed) in the space of the aspiration channel under the action of the air flow starts together with the very process of the seeds being separated along different motion paths in the bottom part of the aspiration channel, depending on the fraction of the seeds. Thus, as is seen in the presented graphic relations, the velocities and accelerations of the heavy fraction seeds are greater after their departure from the cone-shaped seed spreader and during their further movement in the air flow in the space of the aspiration channel. As a result of that, the heavy fraction seeds move securely closer to the aspiration channel central pipe, while the medium fraction seeds – farther from it. At the same time, the light fraction seeds move upwards and the stream of air carries them away outside the aspiration separator.

CONCLUSIONS

1. The mathematical model has been developed for the motion of the particle after its departure from the cone-shaped seed spreader and the system of differential equations has been generated for the motion of the material particle (seed) at this stage of movement.

2. The analytical solution has been obtained for the system of differential equations of the motion of the particle in the vertical air flow of the aspiration channel, which has enabled obtaining with the assistance of the PC the graphical relations for the particle's motion path, its velocity and acceleration after its departure from the cone-shaped seed spreader as functions of time at specific values of the design, kinematic and dynamic parameters of the aspiration separator.

3. As has been shown by the results of the PC-assisted numerical modelling of the motion paths of the material particles (seeds) in the heavy and medium fractions, they move on different paths, that is, the heavy fraction seeds, after their departure from the cone-shaped seed spreader and during their further advancement in the air flow in the space of the aspiration channel, move closer to the pipe in the aspiration channel. Also, their velocities and accelerations are greater, than the same kinematic characteristics of the medium fraction seeds. At the same time, the light fraction seeds travel under the action of the air flow upwards and outside from the aspiration separator.

REFERENCES

- Badretidinov, I., Mudarisov, S., Tuktarov, M., Dick, E. & Arslanbekova, S. 2019. Mathematical modelling of the grain material separation in the pneumatic system of the grain cleaning machine. *Journal of Applied Engineering Science* **17**(4), 529–534. doi: 10.5937/jaes17-22640
- Bernik, P.S. & Palamarchuk, I.P. 1996. Conveyor vibration machines for finishing and handling treatment. Kiev, Vöshaja škola, 237 pp.
- Brăcăcescu, C., Pirna, I., Sorica, C., Popescu, S. & Stan, O. 2012. Experimental research on influence of functional parameters of gravity separator on quality indicators of separation process with application on cleaning of wheat seeds. *Engineering for Rural Development* **11**, 16–21.
- Brăcăcescu, C., Tenu, I., Mircea, C. & Bunduchi, G. 2019. Experimental research on influence of functional parameters of combined installations designed at separating the impurities out of cereal seeds. E35 Web of Conferences, Vol 112, Article no 03004, 8th Int Conf on Thermal Equipment, Renewable Energy and Rural Development. doi: 10.1051/e3sconf/201911203004

- Bulgakov, V., Nikolaenko, S., Holovach, I., Adamchuk, V., Kiurchev, S., Ivanovs, S. & Olt, J. 2020. Theory of grain mixture particle motion during aspiration separation. *Agronomy Research* **18**(1), 18–37. doi.10.15159/AR.20.057
- Burkov, A.I. 1991. Research into work process of closed pneumatic system in seed-cleaning machine. Thesis for degree of Candidate of Sciences. Kirov, 217 pp.
- Khamyev, V., Gulyev, A. & Boiko, A. 2018. Justification of the design of pneumatic sorting machine for the preparation of selection seeds. *MATEC Web of Conferences* **224**, 6 pp. doi: 10.1051/mateconf/201822405008
- Kharchenko, S. Borshch, Y. & Abduev, M. 2017. Efficiency of stratification of grain mixes at their cleaning in the pneumo separating channels of grain separators. *National interagency scientific and technical collection. Design, production and operation of agricultural machines* **47**(1), Kropyvnytskyi: TsNTU, pp. 253–260.
- Kotov, V.V. 2002. Determining velocity of grain in air flow. *Technologies and Mechanical Means in Field Husbandry*, Zernograd, pp. 137–140.
- Kroulik, M., Hula, J. & Rybka, A. 2016. Pneumatic conveying characteristics of seeds in a vertical ascending airstream. *Research in Agricultural Engineering* **62**(2), 56–63.
- Kyurchev, S.V. & Kolodiy, A.S. 2012. Analysis of methods to improve agricultural crop capacity and requirements to separated material. In: *Proceedings of Scientific Papers*, Vinnitsa National Agrarian University, **11**(2), pp. 322–327.
- Kyurchev, S.V. & Kolodiy, A.S. 2015. Multi-criterion analysis of existing seed separators with different operating devices. In: *Bulletin of Kharkiv National Technical University of Agriculture* **156**(1), 86–92.
- Leshchenko, S.M., Vasilkovsky, A.N., Vasilkovsky, M.I. & Gontšarov, V.V. 2009. Raising efficiency of pre-treatment of grain mixtures. In: *Agricultural Machinery*, Lutsk, **18**, pp. 230–234.
- Panasiewicz, M. 1999. Analysis of the pneumatic separation process of agricultural materials. *International Agrophysics* **13**(2), 233–239.
- Panasiewicz, M., Sobczak, P., Mazur, J., Zawisłak, K. & Andrejko, D. 2012. The technique and analysis of the process of separation and cleaning grain materials. *Journal of Food Engineering* **109**(3), 603–608. doi: 10.1016/j.jfoodeng.2011.10.010
- Poturayev, V.N. & Franchuk, V.P. 1970. Selected theoretical prerequisites for research into mechanics of motion of thick loose load layer under the action of vibration. Kiev, *Naukova Dumka*, pp. 173–181.
- Saitov, V.E., Farafanov, V.G., Gataullin, R.G. & Saitov, A.V. 2018. Research of a diametrical fan with suction channel. *IOP Conf. Series: Materials Science and Engineering* **457**, 6 pp, doi: 10.1088/1757-899X/457/012009
- Saitov, V.E., Kurbanov, R.F. & Suvorov, A.N. 2016. Assessing the Adequacy of Mathematical Models of Light Impurity Fractionation in Sedimentary Chambers of Grain Cleaning Machines. *Procedia Engineering* **150**, 107–110. doi: 10.1016/j.proeng.2016.06.728
- Stepanenko, S. 2017. Research pneumatic gravity separation grain materials. In: *Scientific Proceedings V International scientific-technical conference 'Agricultural machinery'*, **2**, 143–145.
- Vasilkovsky, M.I., Goncharova, S.J. & Leshchenko, S.M. 2007. Substantiation of parameters for grain separation in inclined air flow. Design, Production and Operation of Agricultural Machines: *Nationwide Interagency Research and Technology Collected Papers*. Kirovograd National Technical University, Kirovograd, **37**, 132–137.